

AUTOMATION FOR
SMART MANUFACTURING

SHIHLIN AC MOTOR DRIVE SL3/SC3/SS2/SE3/SF3/SA3



About Shihlin Electric

Shihlin Electric & Engineering Corp. established in 1955, has devoted to researching and developing power related products, which cover Automobile Equipment System, Breaker Switchgear & System, Heavy Electric System, and Factory Automation. Our persistent belief of "improving over time" in running the operation and corporate development has not only made us a leader in the domestic market, but also performed splendidly in the overseas market. To make our brand awareness highly recognized, we perform cautious deployments and work hard on overseas marketing and sales.

The setup of overseas branches and factories had compliance with the rapid growth of product demand and to cater to the service of customer worldwide. Shihlin Electric, even with over 60 years of experiences, is still improving itself to better keep up with the globalization. Now, we spare no effort in searching for suitable business partner and expand our brand into global markets. We provide not just the qualified products but also excellent service and professional knowledge.

Now, with to the advance of science and technology, the market demand for electrical product would only grow exponentially. We hold great vision for the coming future. As we are in search of excellence, we do will take part in global competition

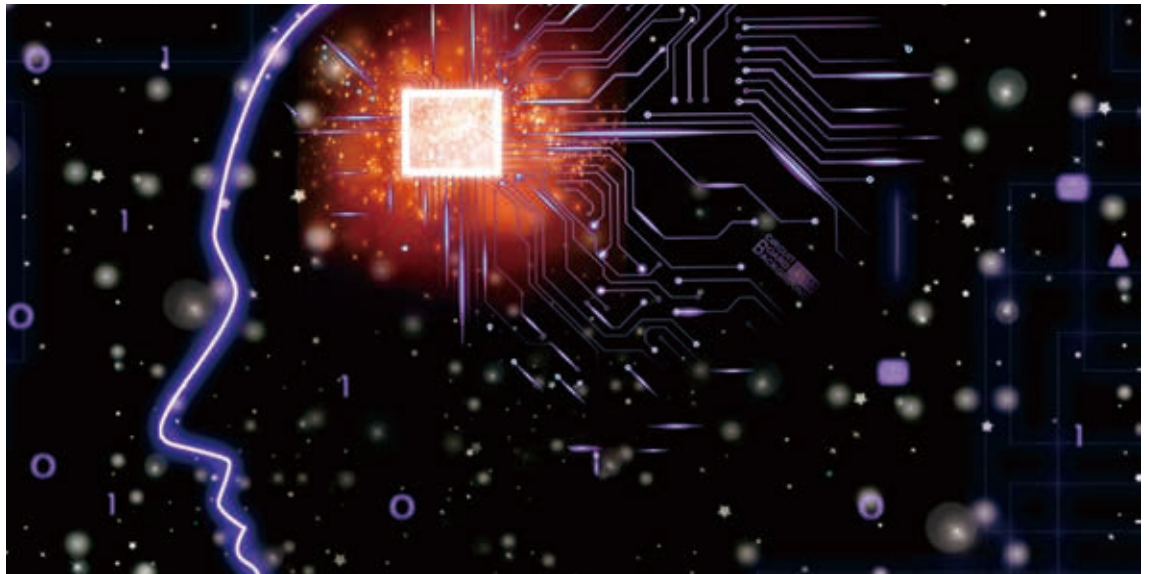

Core Business Units

- *Transmission & Distribution Electrical Products
- *Power Control, Switches & Breakers
- *Factory Automation Products
- *Automotive Electrical Component Products

Table of Contents



Shihlin Drive

Comparison Table

01

SL3 series

Mini AC Drive

03

SC3 series

Compact AC Drive with Vector Control

09

SS2 series

General Vector Control AC Drive

17

SE3 series

High Speed Closed Loop/Communication AC Drive

25

SF3 series

Communication Vector Control AC Drive

35

SA3 series

Advanced Closed Loop Communication AC Drive

45

Optional Accessory

Accessories and Optional Equipment

57

Shihlin Drive Comparison Table



| Series | | SL3 | SC3 | SS2 |
|--------------------------------------------------------------|-------------------------------------------|----------------------------------------------|--------------------------------------------------------------------------------------|----------------------------------------------------|
| Voltage & Capacity | 1 ϕ 200~240V | 0.4~2.2kW | 0.2~2.2kW | 0.4~2.2kW |
| | 3 ϕ 200~240V | - | 0.2~3.7kW | 0.4~3.7kW |
| | 3 ϕ 380~480V | 0.4~2.2kW | 0.4 ~ 2.2kW | 0.4~5.5kW |
| Control Mode | V/F | ○ | ○ | ○ |
| | SVPWM | - | ○ | ○ |
| | General Flux Vector Control | - | ○ | ○ |
| | Sensorless Vector Control | - | - | - |
| | Closed-loop V/F Control (with PG card) | - | - | - |
| | Closed-loop Vector Control (with PG card) | - | - | - |
| | Torque Control (with PG card) | - | - | - |
| Overload Current Rating HD: Heavy Duty ND: Normal Duty | | 150% 60s, 200%1s | For Frame A/B: 150% 60s, 200%1s For Frame C/D: HD: 150% 60s ND: 120% 60s | 150% 60s, 200%1s |
| Input Terminal | Digital | 4 (SINK) | 4 (SINK/SOURCE) | 6 (SINK/SOURCE) |
| | Analog | "1 point (V/I switchable) (4~20mA/0~10V)" | "1 point (V/I switchable) (4~20mA/0~10V)" | "2 points (V/I switchable) (4~20mA/0~10V/0~5V)" |
| | Pulse | - | - | - |
| Output Terminal | Relay | 1 point (A/C) | 1 point (A/C) | 1 point (A/B/C) |
| | Open Collector | - | - | 1 point |
| | Analog | - | - | "1 point (PWM voltage) (DC 0~10V)" |
| | Pulse | - | - | - |
| Braking Unit | | - | Built in: Frame B and above model | Built in |
| RFI filter | | Built in (Always on) | Built in | Built in (Always on) |
| DC Reactor Connector | | - | - | - |
| Communication Function (Including Expansion Cards) | Modbus RTU & ASCII (Built in) | ○ | ○ | ○ |
| | Profibus DP | - | - | - |
| | DeviceNet | - | - | - |
| | Ethernet | - | - | - |
| | Modbus TCP | - | - | - |
| | CANopen | - | - | - |
| | EtherCAT | - | - | - |
| | I/O Expansion | - | - | - |
| Detachable Keypad | | - | - | - |
| Certification | | CE | CE | CE |
| Enclosure Type | | IP20 | IP20 | IP20 |



| Series | | SE3 | SF3 | SA3 |
|--------------------------------------------------------------|-------------------------------------------|-------------------------------------------------------|------------------------------------------------------------------------|------------------------------------------------------------------------|
| Voltage & Capacity | 1ø 200~240V | 0.4~2.2kW | - | - |
| | 3ø 200~240V | 0.4~15kW | - | 0.75~132kW |
| | 3ø 380~480V | 0.4~22kW | 3.7~355kW | 0.75~355kW |
| Control Mode | V/F | ○ | ○ | ○ |
| | SVPWM | ○ | ○ | ○ |
| | General Flux Vector Control | ○ | ○ | ○ |
| | Sensorless Vector Control | ○ | ○ | ○ |
| | Closed-loop V/F Control (with PG card) | ○ | - | ○ |
| | Closed-loop Vector Control (with PG card) | ○ | - | ○ |
| | Torque Control (with PG card) | ○ | - | ○ |
| Overload Current Rating HD: Heavy Duty ND: Normal Duty | | "HD: 150% 60s, 200% 3s ND: 120% 60s, 150% 3s" | "HD: 150% 60s ND: 120% 60s" | "HD: 150% 60s, 200% 3s ND: 120% 60s" |
| Input Terminal | Digital | 6 (SINK/SOURCE) | 10 (SINK/SOURCE) | 10 (SINK/SOURCE) |
| | Analog | "2 points (V/I switchable) (4~20mA/0~10V/-10~10V)" | "3 points (V/I switchable) (0~20mA/0~10V/-10~10V)" | "3 points (V/I switchable) (4~20mA/0~10V/-10~10V)" |
| | Pulse | "1 point (0~100kHz) (Using D/I M2)" | "1 point (0~100kHz) (Using D/I HDI)" | "1 point (0~100kHz) (Using D/I HDI)" |
| Output Terminal | Relay | 1 point (A/B/C) | 2 points (A/B/C, A/B/C) | 2 points (A/B/C, A/B/C) |
| | Open Collector | 1 point | 2 points | 2 points |
| | Analog | 1 point (0~10V/0~20mA/4~20mA) | 2 points (0~10V/0~20mA) | 2 points (0~10V/0~20mA) |
| | Pulse | 1 point(0~100kHz) | 1 point(0~100kHz) | 1 point(0~100kHz) |
| Braking Unit | | Built in | Built in: Frame A, B, C | Built in: Frame A, B, C |
| RFI filter | | Built in | Built in | Built in |
| DC Reactor Connector | | Built in: Frame C and above | Built in | Built in |
| Communication Function (Including Expansion Cards) | Modbus RTU & ASCII (Built in) | ○ | ○ | ○ |
| | Profibus DP | ○ | ○ | ○ |
| | DeviceNet | ○ | ○ | ○ |
| | Ethernet | ○ | ○ | ○ |
| | Modbus TCP | ○ | ○ | ○ |
| | CANopen | ○ | ○ | ○ |
| | EtherCAT | ○ | ○ | ○ |
| | I/O Expansion | ○ | ○ | ○ |
| Detachable Keypad | | ○ | ○ | ○ |
| Certification | | CE | CE | CE |
| Enclosure Type | | IP20 | "Frame A, B, C: IP20 Frame D and above: IP00 (IP20 is optional)" | "Frame A, B, C: IP20 Frame D and above: IP00 (IP20 is optional)" |

SL3 series

Mini AC Drive



Product Range

| Model | | kW (HP) | 0.4 (0.5) | 0.75 (1) | 1.5 (2) | 2.2 (3) |
|-------|-----|---------|--------------|-------------|------------|------------|
| SL3 | 021 | 1Ø 220V | | | | |
| | 043 | 3Ø 440V | | | | |

Product Feature

Save space, easier installation

Mini design, the size is smaller than all previous models. Choose between din rail installation and screw installation, save installation space effectively.



Intuitive Layout And Simple Operation

Power input on top and motor output at bottom, reduce the chance of wrong wiring. Built-in keypad with VR knob, easy to adjust frequency.

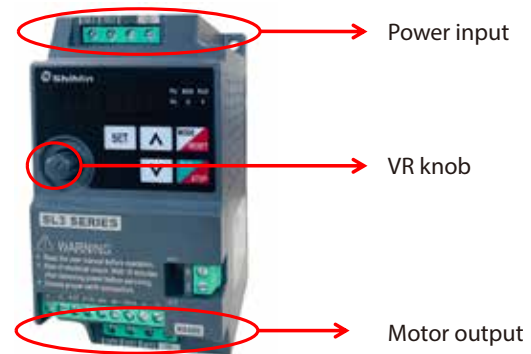

Dual Communication Interface

With two types of RS485 interface, users can easily control multiple units through communication.

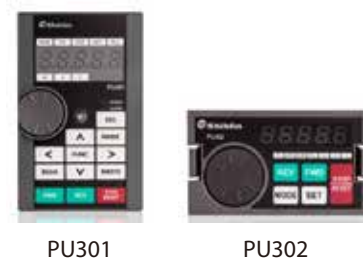
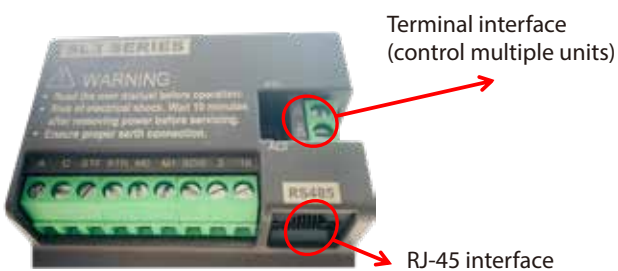

Supports exterior keypad: DU06, DU08S, PU301, PU302
*Note:RS485 and keypad will not work simultaneously.

More than enough overload protection

Over current protection level (OC) 260%; Over current limit level (LT) 220%, provides stronger driving ability and longer lifetime.

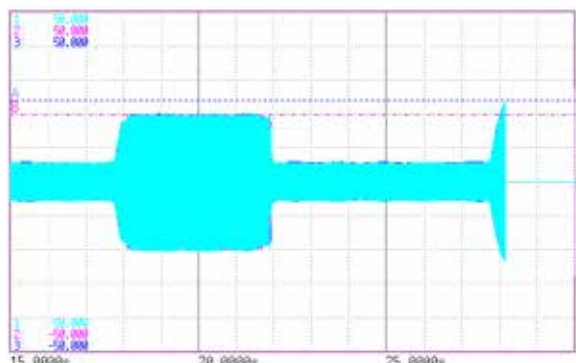

Environmental Resistance Improve

Optimized air channel

Reduce the dust that goes inside, increase the lifetime of SL3 inverter.

Added structure to improve air channel.

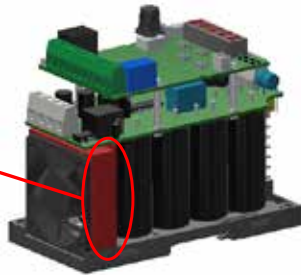

Improved isolation design

Add isolation (thermal conductive) silicon film in Frame A to increase creepage distance.

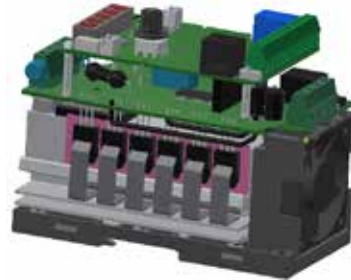

Lower motor noise

Low noise carrier frequency control(Soft-PWM) can turn motor's metallic noise into a more pleasing buzz. SL3 is embedded with improved algorithm to further lower motor noise.

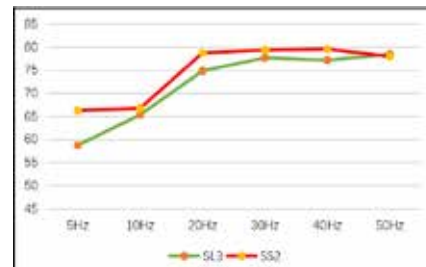
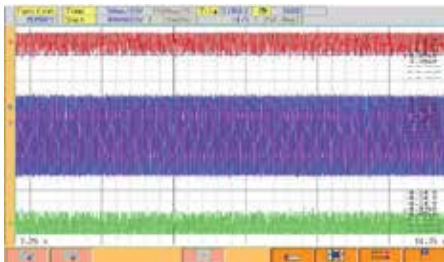

Noise comparison (db)

Compared with previous products, the noise is substantially lower at low speed.

Lower false alarm chance

With better current stall prevention function, the current can be regulated much faster which lowers the chance of triggering alarm.

Other specialized feature

- Built-in Modbus communication, Baud rate up to 38400bps.
- Built-in PID controller for constant pressure and constant temperature applications.
- Alarm record: 12 sets of records with 2 detailed record, check the operating status with full detail.
- Regeneration avoid function: monitor DC bus voltage in real-time and suppress DC bus voltage when it increase abnormally, prevents over voltage alarm.
- Automatic carrier frequency adjustment, prevent IGBT overheat(NTC) alarm.
- Built-in RFI filter for all range, suppress electric interference effectively.
- Free communication software SL-INVConfigurator, for testing, monitoring, upload and save parameters and much more.



SL3

Electric Specification

220V series single phase

| Frame | | A | | B | |
|--------------------------|------------------------------------|----------------------------------------------------------------|------|------|-----|
| Model SL3-021- □□□ K- □□ | | 0.4 | 0.75 | 1.5 | 2.2 |
| Inverter Output | Rated output capacity (kVA) | 1 | 1.5 | 2.5 | 4.2 |
| | Rated output current (A) | 2.7 | 4.5 | 8 | 11 |
| | Applicable motor capacity (HP) | 0.5 | 1 | 2 | 3 |
| | Applicable motor capacity (kW) | 0.4 | 0.75 | 1.5 | 2.2 |
| | Overload current rating | 150% 60 seconds, 200% 1 seconds (inverse-time characteristics) | | | |
| Carrier frequency (kHz) | | 1~15kHz | | | |
| Maximum output voltage | | 3 phase 200-240V | | | |
| Power supply | Rated input current (A) *Note 1 | 6.5 | 9.3 | 15.7 | 24 |
| | Rated input AC voltage/ frequency | single phase 200-240V 50Hz/60Hz | | | |
| | Permissible AC voltage fluctuation | single phase 170-264V 50Hz/60Hz | | | |
| | Permissible frequency fluctuation | ±5% | | | |
| | Power supply capacity (kVA) | 1.5 | 2.5 | 3.5 | 6.4 |
| | Cooling method | Fan cooling | | | |
| Weight (kg) | | 0.6 | 0.6 | 0.6 | 0.8 |

440V series three-phase

| Frame | | B | | | |
|---------------------------|------------------------------------|----------------------------------------------------------------|------|------|------|
| Model SL3-043 - □□□ K- □□ | | 0.4 | 0.75 | 1.5 | 2.2 |
| Inverter Output | Rated output capacity (kVA) | 1 | 2 | 3 | 4.6 |
| | Rated output current (A) | 1.5 | 2.6 | 4.2 | 6 |
| | Applicable motor capacity (HP) | 0.5 | 1 | 2 | 3 |
| | Applicable motor capacity (kW) | 0.4 | 0.75 | 1.5 | 2.2 |
| | Overload current rating | 150% 60 seconds, 200% 1 seconds (inverse-time characteristics) | | | |
| Carrier frequency (kHz) | | 1~15kHz | | | |
| Maximum output voltage | | 3 phase 380-480V | | | |
| Power supply | Rated input current (A) *Note 1 | 1.8 | 3.2 | 4.3 | 7.1 |
| | Rated input AC voltage/ frequency | 3 phase 380-480V 50Hz/60Hz | | | |
| | Permissible AC voltage fluctuation | 3 phase 323-528V 50Hz/60Hz | | | |
| | Permissible frequency fluctuation | ±5% | | | |
| | Power supply capacity (kVA) | 1.5 | 2.5 | 4.5 | 6.9 |
| | Cooling method | Fan cooling | | | |
| Weight (kg) | | 0.8 | 0.8 | 0.85 | 0.85 |

Common Specification

| | | |
|---------------------------------------------------|-------------------------|---------------------------------------------------------------------------------------------------------------------------------------------------------------------------------------------------------------------------------------------------------------------------------------------------------------------------------------------------------------------------------------------------------------------------------------------------------------------------------------------------|
| Control method | | V/F control |
| Output frequency range | | 0.00~599.00Hz |
| Frequency setting resolution | Digital setting | 0.01Hz |
| | Analog setting | Maximum output frequency±0.1% |
| Output frequency accuracy | Digital setting | Maximum target frequency±0.01% |
| | Analog setting | Maximum target frequency±0.1% |
| Starting torque | | 150% / 5Hz automatic torque boost |
| V/F characteristics | | Constant torque curve, variable torque curve, five-point VF curve |
| Acceleration / deceleration curve characteristics | | Linear acceleration /deceleration curve, S shape acceleration/deceleration curve 1 & 2 & 3 |
| Drive motor type | | Induction motor (IM) |
| Stalling protection | | The stalling protection level can be set to 0~200% |
| Target frequency setting | | Up down button, VR knob setting, DC 0~5V/10V signal, DC 4~20 mAsignal, multi-speed stage level setting, communication setting, PWM pulse setting. |
| Keypad | Operation monitoring | Output frequency, output current, output voltage, electronic thermalaccumulation rate, temperature rising accumulation rate, output power, analog input signal value, digital input and output terminal status...; alarm history 12 sets with operation details of the latest two sets |
| | LED indicator (6) | Frequency monitoring indicator, voltage monitoring indicator, current monitoring indicator, motor running indicator, mode switch indicator, PU mode indicator |
| Communication function | | RS-485 communication, choose between Shihlin/Modbuscommunication protocol |
| Protection mechanism / alarm function | | Output short circuit protection, over-current protection, over-voltageprotection, under-voltage protection, motor over-heat protection, IGBTmodule over-heat protection, communication error protection, PID errorprotection, memory error protection, CPU error protection, stallprevention, module over-heat protection, input power fail protection, terminal 3-5 disconnect protection, over torque protection, Currentleakage to ground protection, hardware detect circuit error protection |
| Environment | Ambient temperature | -10 ~ +40°C (non-freezing) |
| | Ambient humidity | Below 90%Rh (non-condensing) |
| | Storage temperature | -20 ~ +65°C |
| | Surrounding environment | Indoor, no corrosive gas, no flammable gas, no flammable powder. |
| | Altitude | Altitude below 2000 meters, when altitude is above 1,000m, derate the rated current 2% per 100m |
| | Vibration | Vibration below 5.9m/s ² (0.6G) |
| | Grade of protection | IP20 |
| | Over voltage level | II |
| Degree of environmental pollution | | 2 |
| Class of protection | | Class I |
| International certification | | CE |

Wiring Diagram

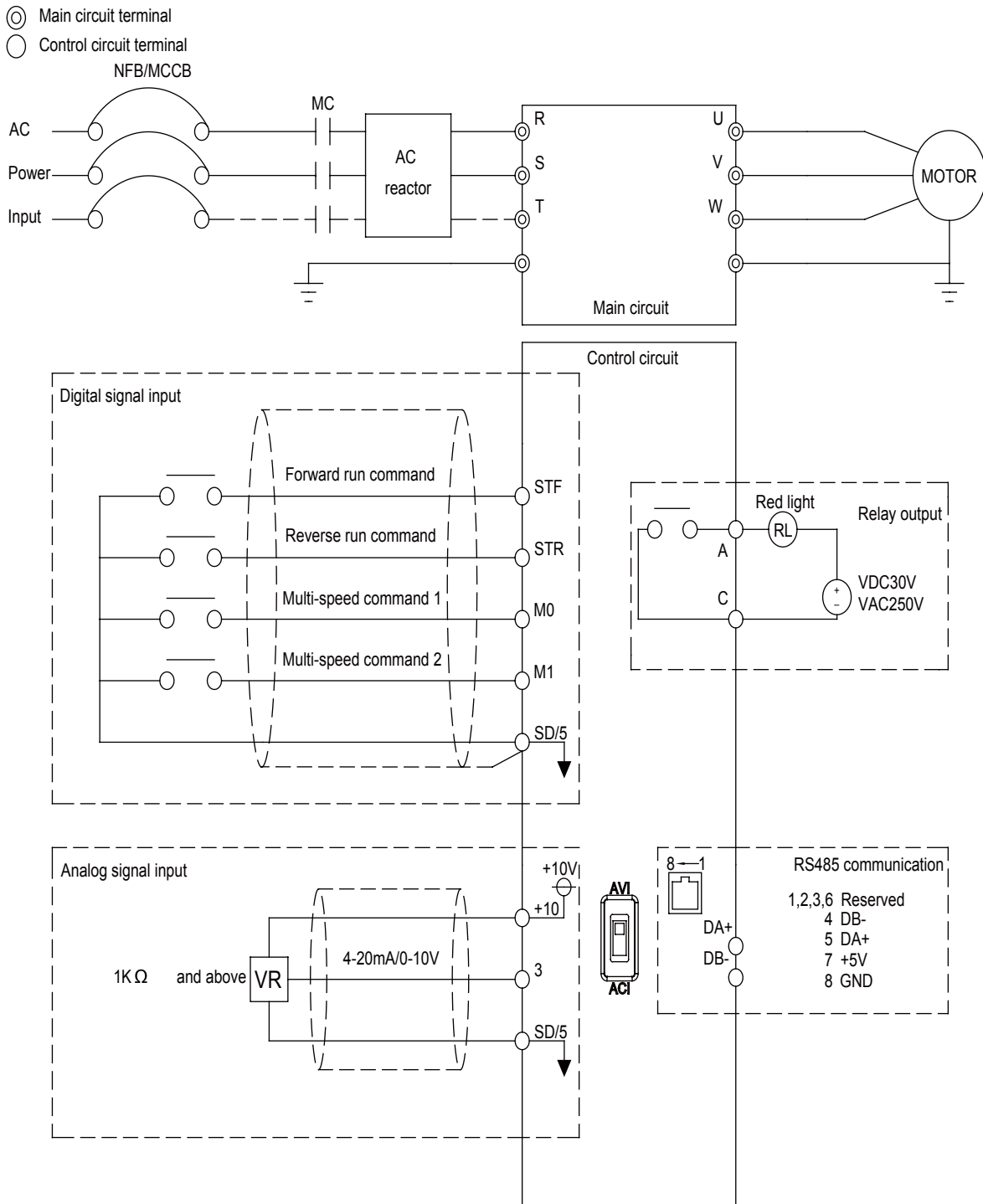

- Note :
- 1.All series include built-in RFI filters, in order to comply with CE regulations; Please refer to manual.
 - 2.When exterior keypad is connect to RJ45 port, RS485 by DA+/DB- will not work;
 - 3.When switching terminal 3-5 voltage/ current input, please check the ACI/AVI switch position, and check parameter 02-20 (P.17) setting.



SL3

Appearance and dimensions

Frame A

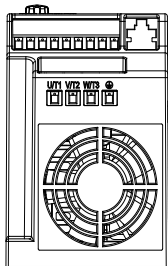
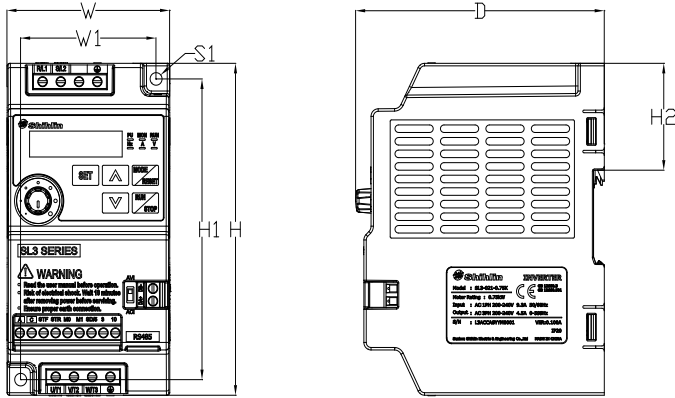

| Model | W | W1 | H | H1 | H2 | D | S1 |
|---------------|----|----|-----|-----|------|-----|--------------------------------------|
| SL3-021-0.4K | 68 | 56 | 132 | 120 | 42.5 | 104 | 5 (tighten torque 20~25kgf.cm) |
| SL3-021-0.75K | | | | | | | |
| SL3-021-1.5K | | | | | | | |

Frame B

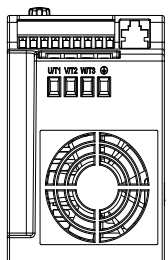
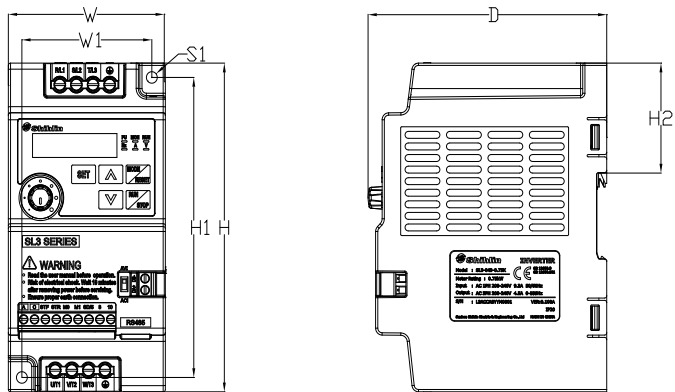

| Model | WW | 1H | H1 | H2 | DS | 1 | |
|---------------|----|------|-----|-------|------|-----|--------------------------------------|
| SL3-021-2.2K | 72 | 59.5 | 142 | 129.5 | 42.5 | 110 | 5 (tighten torque 20~25kgf.cm) |
| SL3-043-0.4K | | | | | | | |
| SL3-043-0.75K | | | | | | | |
| SL3-043-1.5K | | | | | | | |
| SL3-043-2.2K | | | | | | | |

SC3 series

Compact Inverter with
Vector Control

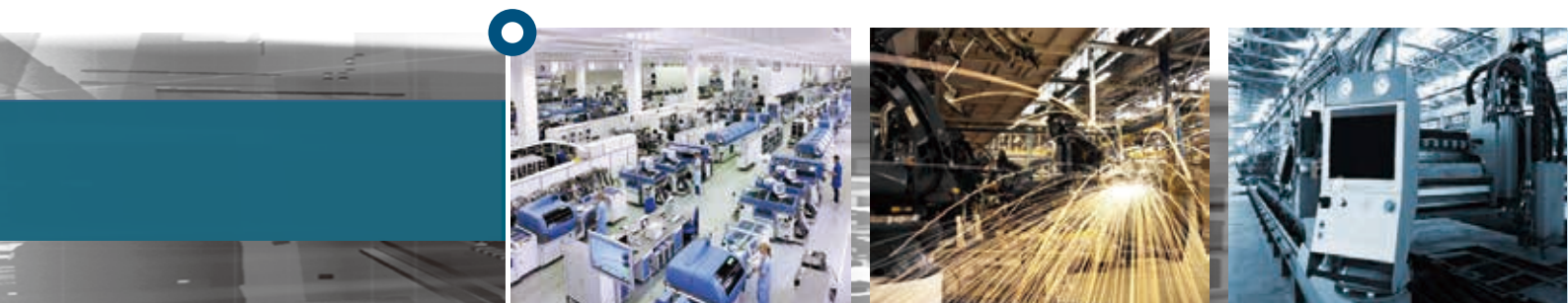

Product Range

| Model | | kW (HP) | 0.2 (0.25) | 0.4 (0.5) | 0.75 (1) | 1.5 (2) | 2.2 (3) | 3.7 (5) | 5.5 (7.5) | 7.5 (10) | 11 (15) | 15 (20) | 18.5 (25) | 22 (30) | | |
|-------|-----|--------------|---------------|--------------|-------------|------------|------------|------------|--------------|-------------|------------|------------|--------------|------------|--|--|
| SC3 | 021 | 1 phase 220V | ■ | | | | | | | | | | | | | |
| | 023 | 3 phase 220V | ■ | | | | | | | | | | | | | |
| | 043 | 3 phase 440V | | | ■ | | | | | | | | | | | |

Main Features

- * High performance vector control
- * Built-in operation wheel
- * Full PCB coating and isolated air duct
- * Dual RS485 communication interface
- * Built-in PID controller
- * Built-in RFI filter
- * Built-in Modbus communication(up to 115200bps)
- * Drive PM motor(Customized model)
- * Built-in proportion linkage function
- * Built-in 8 sets of programmed operation function
- * Built-in 5 point V/F curve
- * Built-in multi-function monitoring
- * Built-in energy saving algorithm
- * Built-in low current/overtorque detection
- * Cooling fan auto on/off in different temperature
- * 12 sets of alarm record, with detailed information of the latest 2 alarm (with frequency / current / voltage / temperature rising rate /DC bus voltage /operation time record)
- * Din rail installation
- * External keypad
- * Output frequency up to 599Hz
- * Output short circuit function

Model Identification

| Series | Voltage level | Capacity | Version |
|------------|-----------------------------------------------------------------------------|----------|------------------------------------------------------------------------------|
| SC3 series | 043 : three phase 440V 023 : three phase 220V 021 : single phase 220V | 0.75kW | None : General model -xy : Customized or specialized or region difference |



Product Features

Built-in RFI filter

- A screw switch to turn on/off RFI filter, reduce electromagnetic interference.

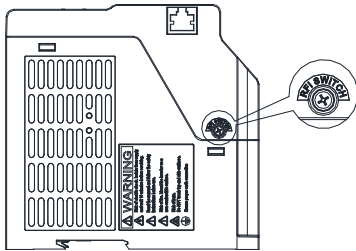

Note: Please refer to manual for installation details.

Coating & Isolated Air Duct

- All PCB is coated with insulation material.
- Heat sink is separated and isolated from the PCB, prevent dust/oil from contacting electronic components.

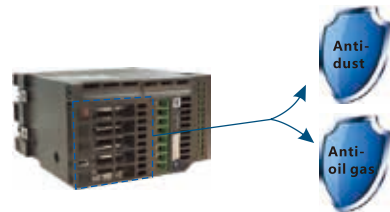

Note: Please do not install the inverter in a heavily polluted environment without any protection.

Dual RS485 interface

- Screw terminal for easy connection with multiple machines.
- RJ45 for easy connection with external keypad.



Note: External keypad and RS485 cannot work at the same time.

Easy Maintenance

- Fan is removable.
- The fan is designed on the top to effectively reduce the impact of falling dust, and the terminal wiring will not affect the maintenance of the fan.



Optimized Operation Wheel Design

- The position of the operation wheel is lower than the front cover, avoiding all external force from damaging the wheel.



Grouping Parameters - Easy Setup

| Group | Parameter Number | Name | Setting Range |
|-------|------------------|------------------------------|----------------------------------------------|
| 01-00 | P.1 | Maximum frequency | 0.00 ~ 01-02 (P.18) Hz |
| 01-01 | P.2 | Minimum frequency | 0 ~ 120.00Hz |
| 01-02 | P.18 | High-speed maximum frequency | 01-00 (P.1) ~ 599.00Hz |
| 01-03 | P.3 | Base frequency | 50Hz system setting: 0 ~ 599.00Hz |
| | | | 60Hz system setting: 0 ~ 599.00Hz |
| 01-04 | P.19 | Base voltage | 0 ~ 1000.0V |
| | | | 99999: Change according to the input voltage |

SC3 series: Similar functions are grouped into same sectors instead of sequence numbers.



SC3

Electrical Specifications

220V Series single-phase

| Frame | | A | | | B | |
|-------------------------|-----------------------------------------|--------------------------------------------------------------|------|------|------|-----|
| Model SC3-021- □□□ K-xy | | 0.2 | 0.4 | 0.75 | 1.5 | 2.2 |
| Output | Rated output capacity (kVA) | 0.6 | 1 | 1.5 | 2.5 | 4.2 |
| | Rated output current (A) | 1.8 | 2.7 | 4.5 | 8 | 11 |
| | Applicable motor capacity (HP) | 0.25 | 0.5 | 1 | 2 | 3 |
| | Applicable motor capacity (kW) | 0.2 | 0.4 | 0.75 | 1.5 | 2.2 |
| | Overload current rating | 150% 60 seconds 200% 1 second (inverse time characteristics) | | | | |
| | Carrier frequency (kHz) | 1~15kHz | | | | |
| | Maximum output voltage | Three-phase 200-240V | | | | |
| Power supply | Rated power voltage | Single-phase 200-240V 50Hz / 60Hz | | | | |
| | Power voltage permissible fluctuation | Single-phase 170-264V 50Hz / 60Hz | | | | |
| | Power frequency permissible fluctuation | ±5% | | | | |
| | Power source capacity (kVA) | 0.75 | 1.5 | 2.5 | 3.5 | 6.4 |
| | Rated input current(A) (Note1) | 5.4 | 6.5 | 9.3 | 15.7 | 24 |
| Cooling method | Self cooling | Forced air cooling | | | | |
| Weight (kg) | 0.66 | 0.6 | 0.73 | 1.38 | 1.4 | |

220V Series three-phase

| Frame | | A | | | | B | |
|--------------------------|-----------------------------------------|--------------------------------------------------------------|------|------|------|-----|------|
| Model SC3-023 - □□□ K-xy | | 0.2 | 0.4 | 0.75 | 1.5 | 2.2 | 3.7 |
| Output | Rated output capacity (kVA) | 0.6 | 1.2 | 2 | 3.2 | 4.2 | 6.7 |
| | Rated output current (A) | 1.8 | 3 | 5 | 8 | 11 | 17.5 |
| | Applicable motor capacity (HP) | 0.25 | 0.5 | 1 | 2 | 3 | 5 |
| | Applicable motor capacity (kW) | 0.2 | 0.4 | 0.75 | 1.5 | 2.2 | 3.7 |
| | Overload current rating | 150% 60 seconds 200% 1 second (inverse time characteristics) | | | | | |
| | Carrier frequency (kHz) | 1~15kHz | | | | | |
| | Maximum output voltage | Three-phase 200-240V | | | | | |
| Power supply | Rated power voltage | Three-phase 200-240V 50Hz / 60Hz | | | | | |
| | Power voltage permissible fluctuation | Three-phase 170-264V 50Hz / 60Hz | | | | | |
| | Power frequency permissible fluctuation | ±5% | | | | | |
| | Power source capacity (kVA) | 0.75 | 1.5 | 2.5 | 4.5 | 6.4 | 10 |
| | Rated input current(A) (Note1) | 2.1 | 3.2 | 5.6 | 9.3 | 15 | 20.6 |
| Cooling method | Self cooling | Forced air cooling | | | | | |
| Weight (kg) | 0.69 | 0.69 | 0.70 | 0.73 | 1.32 | 1.4 | |

Note 1 : The value of rated input current is not only affected by the power transformer, input reactor and wiring conditions but also fluctuates with the impedance on the power side.

Electrical Specifications

440V Series three-phase

| Frame | | A | | | B | | |
|-------------------------|-----------------------------------------|--------------------------------------------------------------|------|------|------|------|------|
| Model SC3-043- □□□ K-xy | | 0.4 | 0.75 | 1.5 | 2.2 | 3.7 | 5.5 |
| Output | Rated output capacity (kVA) | 1 | 2 | 3 | 4.6 | 6.9 | 9.2 |
| | Rated output current (A) | 1.5 | 2.6 | 4.2 | 6 | 9 | 12 |
| | Applicable motor capacity (HP) | 0.5 | 1 | 2 | 3 | 5 | 7.5 |
| | Applicable motor capacity (kW) | 0.4 | 0.75 | 1.5 | 2.2 | 3.7 | 5.5 |
| | Overload current rating | 150% 60 seconds 200% 1 second (inverse time characteristics) | | | | | |
| | Carrier frequency (kHz) | 1~15kHz | | | | | |
| | Maximum output voltage | Three-phase 380-480V | | | | | |
| Power supply | Rated power voltage | Three-phase 380-480V 50Hz / 60Hz | | | | | |
| | Power voltage permissible fluctuation | Three-phase 323-528V 50Hz / 60Hz | | | | | |
| | Power frequency permissible fluctuation | ±5% | | | | | |
| | Power source capacity (kVA) | 1.5 | 2.5 | 4.5 | 6.9 | 10.4 | 11.5 |
| | Rated input current(A) (Note1) | 1.8 | 3.2 | 4.3 | 7.1 | 10 | 14 |
| Cooling method | Self cooling | Forced air cooling | | | | | |
| Weight (kg) | 0.74 | 0.74 | 0.81 | 1.37 | 1.37 | 1.42 | |

| Frame | | C | | D | | | |
|----------------------------|-----------------------------------------|------------------------------------------------|------------------------------------------------|---------|---------|------|----|
| Model SC3-043- □ K □ KF-xy | | 7.5/11 | 11/15 | 15/18.5 | 18.5/22 | 22 | |
| Output | HD | Rated output capacity (kVA) | 14 | 18 | 25 | 29 | 34 |
| | | Rated output current (A) | 18 | 24 | 32 | 38 | 45 |
| | | Applicable motor capacity (HP) | 10 | 15 | 20 | 25 | 30 |
| | | Applicable motor capacity(kW) | 7.5 | 11 | 15 | 18.5 | 22 |
| | | Overload current rating | 150% 60 seconds (inverse time characteristics) | | | | |
| | Carrier frequency (kHz) | 1~15kHz | | | | | |
| | ND | Rated output capacity (kVA) | 84 | 25 | 29 | 34 | - |
| | | Rated output current (A) | 24 | 32 | 38 | 45 | - |
| | | Applicable motor capacity (HP) | 15 | 20 | 25 | 30 | - |
| | | Applicable motor capacity (kW) | 11 | 15 | 18.5 | 22 | - |
| Overload current rating | | 120% 60 seconds (inverse time characteristics) | | | | | |
| Carrier frequency (kHz) | 1~15kHz | | 1~10kHz | | | | |
| Maximum output voltage | Three-phase 380-480V | | | | | | |
| Power supply | Rated power voltage | Three-phase 380-480V 50Hz / 60Hz | | | | | |
| | Power voltage permissible fluctuation | Three-phase 323-528V 50Hz / 60Hz | | | | | |
| | Power frequency permissible fluctuation | ±5% | | | | | |
| | Power source capacity (kVA) | 16 | 20 | 27 | 32 | 41 | |
| | Rated input current (A) (Note1) | HD | 20 | 26 | 35 | 40 | 47 |
| | | ND | 26 | 35 | 40 | 47 | 54 |
| Cooling method | Forced air cooling | | | | | | |
| Weight(kg) | 2.07 | 2.15 | 3.45 | 3.57 | 3.70 | | |

Note 1 : The value of rated input current is not only affected by the power transformer, input reactor and wiring conditions but also fluctuates with the impedance on the power side.



SC3

Common Specifications

| | | |
|---------------------------------------------------|-----------------------------------|----------------------------------------------------------------------------------------------------------------------------------------------------------------------------------------------------------------------------------------------------------------------------------------------------------------------------------------------------------------------------------------------------------------------------------------------------------------------------|
| Control method | | SVPWM, V/F control, General flux vector control |
| Output frequency range | | 0~599.00Hz |
| Frequency setting resolution | Digital setting | Within 100Hz, the resolution is 0.01Hz Above 100Hz, the resolution is 0.1Hz. |
| | Analog setting | DC 0~5V or 4~20mA signal: 11 bit, DC 0~10V signal: 12 bit. |
| Output frequency accuracy | Digital setting | Maximum target frequency \pm 0.01%. |
| | Analog setting | Maximum target frequency \pm 0.1%. |
| Starting torque | | Under General flux vector control: 180% 3Hz, 200% 5Hz |
| V/F characteristics | | Constant torque curve, variable torque curve, five-point VF curve |
| Acceleration / deceleration curve characteristics | | Linear acceleration / deceleration curve, S shape acceleration /deceleration curve 1 & 2 & 3 |
| Drive motor | | Induction motor (IM) |
| Stalling protection | | The stalling protection level can be set from 0~250%. Default value 150% |
| Target frequency setting | | Built-in keypad setting, DC 0~5V/0~10V signal, DC 4~20 mA signal, multi-speed stage level setting, communication setting. |
| Keypad | Operation monitoring | Output frequency, output current, output voltage, PN voltage, electronic thermal accumulation rate, temperature rising accumulation rate, output power, analog input signal value, external terminal status...; alarm history 12 sets with operation details of the latest two set. |
| | LED indicator(6) | Frequency monitoring indicator, voltage monitoring indicator, current monitoring indicator, motor running indicator, mode switch indicator, PU mode indicator. |
| Communication function | | RS485 communication, choose between Shihlin / Modbus communication protocol, baud rate up to 115200bps. |
| Protection mechanism / alarm function | | Output short circuit protection, over-current protection, over-voltage protection, under-voltage protection, motor over-heat protection (06-00(P.9)), IGBT module over-heat protection, communication error protection, PID error protection, memory error protection, CPU error protection, stall prevention, module over-heat protection, input power fail protection, terminal 3-5 disconnect protection, over torque protection, current leakage to ground protection. |
| Environment | Ambient temperature | -10 ~ +50°C (non-freezing), side by side installation-10~ +40°C (non-freezing). |
| | Ambient humidity | Below 90%Rh (non-condensing). |
| | Storage temperature | -20 ~ +65°C |
| | Surrounding environment | Indoor, no corrosive gas, no flammable gas, no flammable dust. |
| | Altitude | Altitude below 2000 m, when altitude is above 1000 m, derate the rated current 2% per 100 m |
| | Vibration | Vibration below 5.9m/s ² (0.6G) |
| | Grade of protection | IP20 |
| | Over voltage level | II |
| | Degree of environmental pollution | 2 |
| | Class of protection | Class I |
| International certification | | CE |

Wiring Diagram

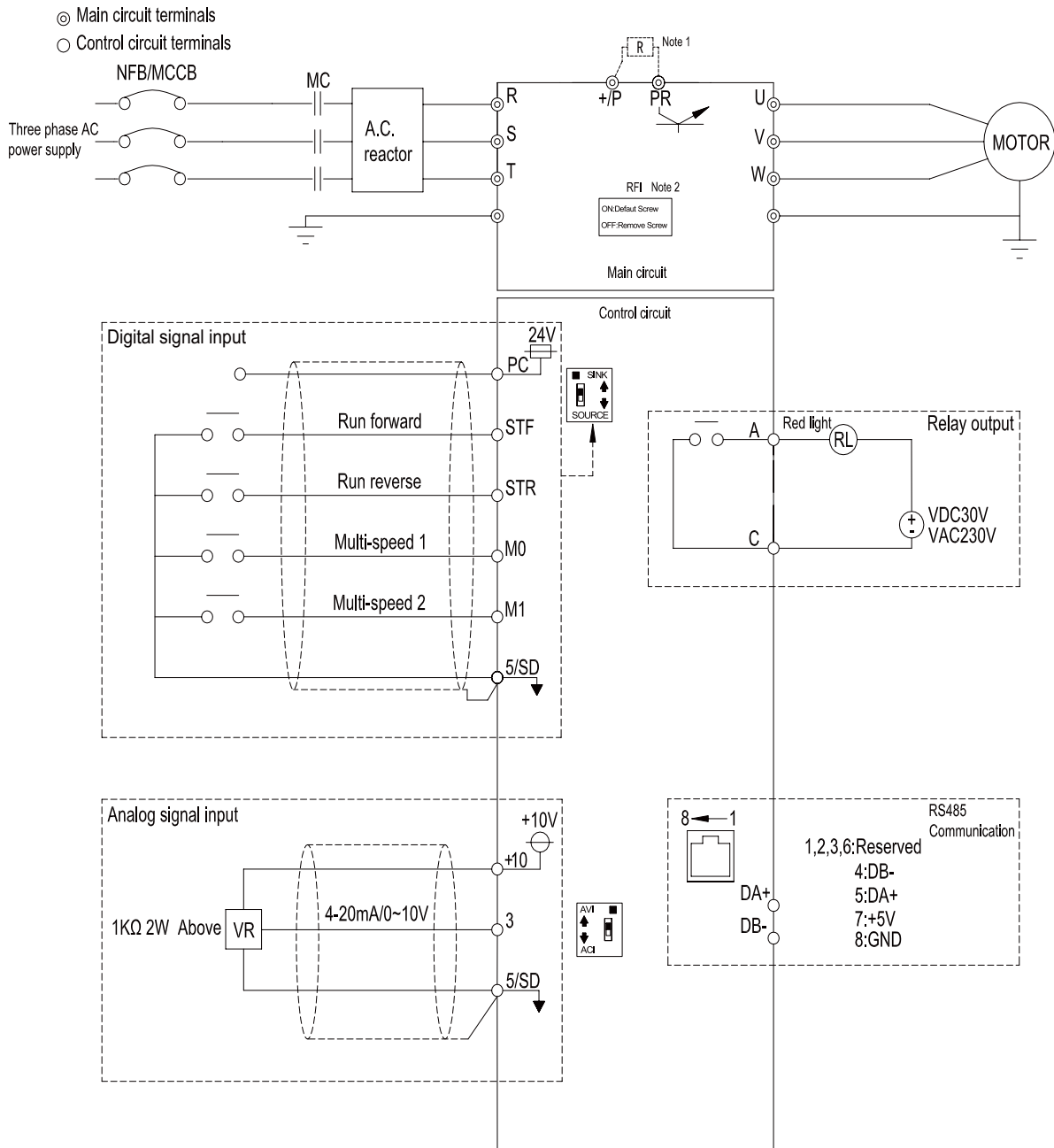

NOTE

1. There is no +/P and PR terminal in frame A (SC3-043-0.4K~1.5K, SC3-023-0.2K~1.5K, SC3-021-0.2K~0.75K.)
2. All series have built-in RFI filter to suppress electromagnetic interference. In order to comply with CE regulations, please refer to relevant instructions in the manual for installation.

Dimensions

Unit : mm

Frame A

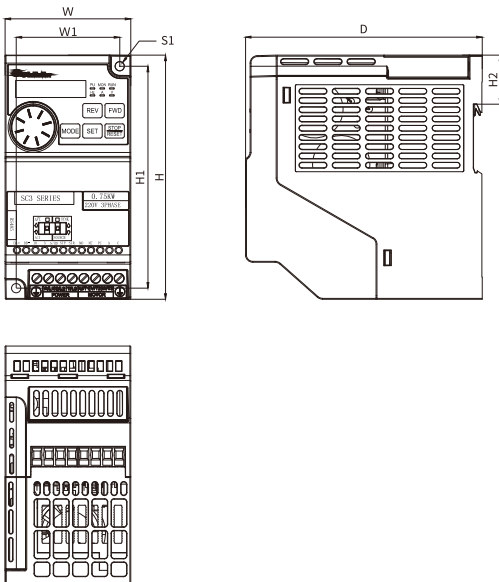

Frame A

| Model type | W (mm) | W1 (mm) | H (mm) | H1 (mm) | H2 (mm) | D (mm) | S1 (mm) |
|---------------|--------|---------|--------|---------|---------|--------|-------------------------------------|
| SC3-021-0.2K | 68 | 56 | 132 | 120 | 26.5 | 128 | 5 Tightening torque: 20-25kgf.cm |
| SC3-021-0.4K | | | | | | | |
| SC3-021-0.75K | | | | | | | |
| SC3-023-0.2K | | | | | | | |
| SC3-023-0.4K | | | | | | | |
| SC3-023-0.75K | | | | | | | |
| SC3-023-1.5K | | | | | | | |
| SC3-043-0.4K | | | | | | | |
| SC3-043-0.75K | | | | | | | |
| SC3-043-1.5K | | | | | | | |

Frame B/C/D

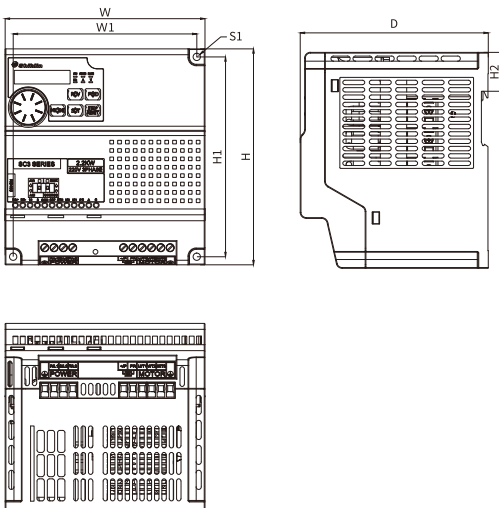

Frame B/C/D

| Model type | W (mm) | W1 (mm) | H (mm) | H1 (mm) | H2 (mm) | D (mm) | S1 (mm) |
|--------------------|--------|---------|--------|---------|---------|--------|---------------------------------------|
| SC3-021-1.5K | 136 | 125 | 147 | 136 | 26.5 | 128 | 5 Tightening torque: 20-25kgf.cm |
| SC3-021-2.2K | | | | | | | |
| SC3-023-2.2K | | | | | | | |
| SC3-023-3.7K | | | | | | | |
| SC3-043-2.2K | | | | | | | |
| SC3-043-3.7K | 132 | 115.6 | 215 | 198.6 | - | 150 | 6.2 Tightening Torque: 20-25kgf.cm |
| SC3-043-5.5K | | | | | | | |
| SC3-043-7.5K/11KF | 175 | 158.6 | 260 | 243.6 | - | 180 | 6.2 Tightening Torque: 20-25kgf.cm |
| SC3-043-11K/15KF | | | | | | | |
| SC3-043-15K/18.5KF | | | | | | | |
| SC3-043-18.5K/22KF | | | | | | | |
| SC3-043-22K | | | | | | | |

SS2 series

General Vector Control Inverter

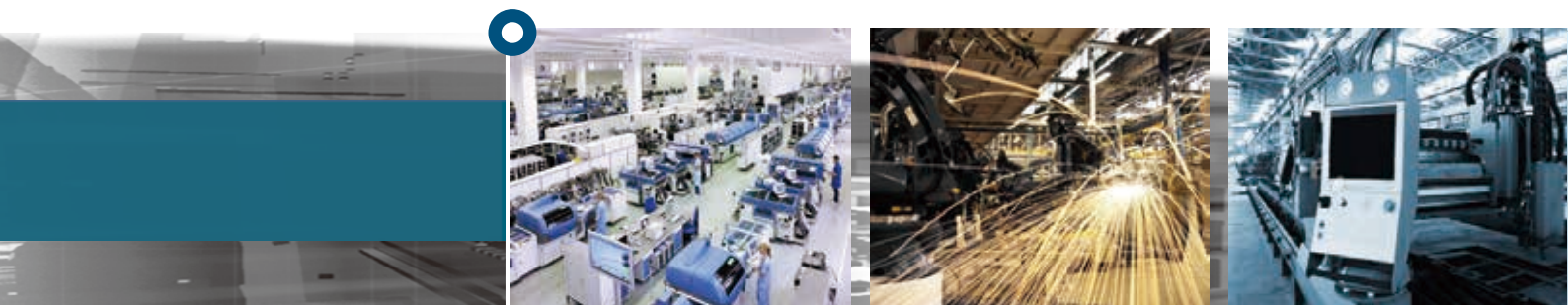

Product Range

| Model | | kW (HP) | 0.4 (0.5) | 0.75 (1) | 1.5 (2) | 2.2 (3) | 3.7 (5) | 5.5 (7.5) | |
|-------|-----|--------------|--------------|-------------|------------|------------|------------|--------------|--|
| SS2 | 021 | 1 phase 220V | ■ | | | | | | |
| | 023 | 3 phase 220V | ■ | | | | | | |
| | 043 | 3 phase 440V | ■ | | | | | | |

Main Features

- * Built-in shuttle knob to adjust output frequency and set parameters easily
- * Built-in RS485 communication interface
- * Support MODBUS and Shihlin communication protocol
- * Built-in proportion linkage control function to support multi inverters connection
- * Maximum 599Hz frequency output
- * Support DIN rail mount
- * The resolution of frequency setting: digital 0.01Hz ; analog 1/1000
- * The accuracy of output frequency: 0.01%
- * Multi-function input/output terminals
- * Support 2 analog setting types: 0-10V and 4-20mA

Model Identification

| Series | Voltage level | Capacity | Version |
|------------|-----------------------------------------------------------------------------|----------|------------------------------------------------------------------------------|
| SS2 series | 043 : three phase 440V 023 : three phase 220V 021 : single phase 220V | 0.75kW | None : General model -xy : Customized or specialized or region difference |



Product Features

General Flux Vector Control Technique

- General flux vector control technique.
- A 32-bit RISC CPU for high-speed computation.
- Starting torque, 150%3Hz.

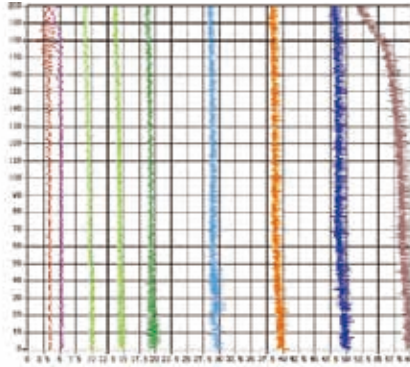

- Speed accuracy is within 1% (0%~100% loading changes).

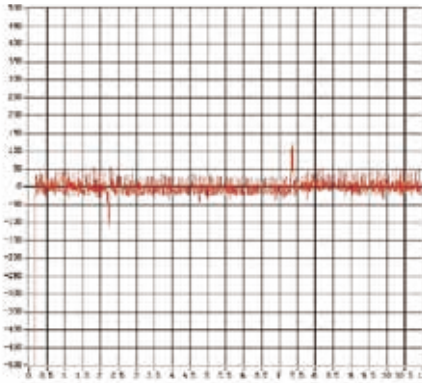

- Motor parameter auto-tuning function.
- Stalling protection level reaches to 250%.

High Performance And Function

- The maximum output frequency up to 599Hz.
- Soft-PWM functions for eliminating motor noises and preventing the temperature of IGBT module too high.
- Built-in energy-saving control function, inverter will control the output voltage automatically in order to reduce the output power losses when inverter is running.
- Cooling fan operation method is selectable.

Built-in Proportion Linkage Function

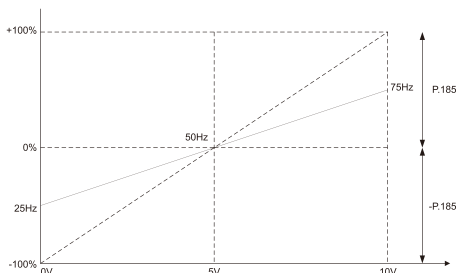

PID Feedback Control Function

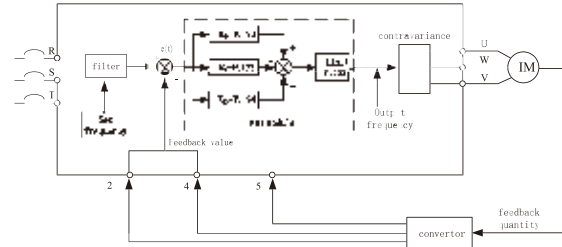

Triangular Wave Function (traverse)

- This is suitable for operations that need traversing and winding movements such as textile operations.

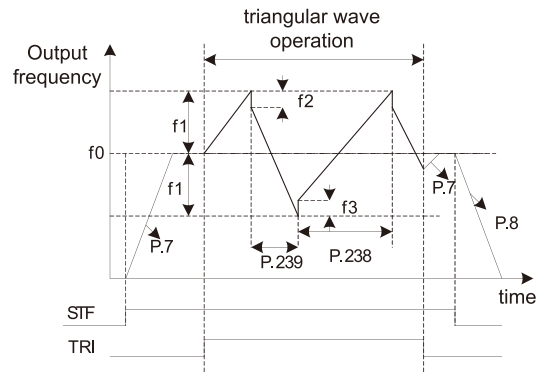

- f0 : Setting value of frequency
- f1 : Generated amplitude for setting frequency ($f_0 \times P.235$)
- f2 : Compensation from acceleration to deceleration ($f_1 \times P.236$)
- f3 : Compensation from deceleration to acceleration ($f_1 \times P.237$)

Built-in Frequency And Parameter Setting Knob





Product Features

PWM Control Function

- The operating frequency can be controlled with the PWM signals output from PLC.
- The terminal M2 can be set as PWM signal input.

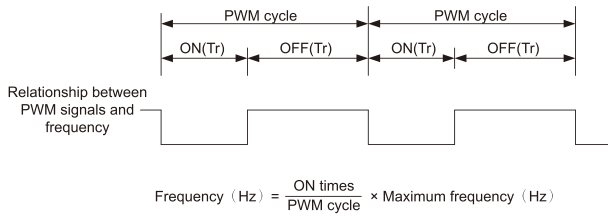

Programmed Operation Mode With Manual Operation

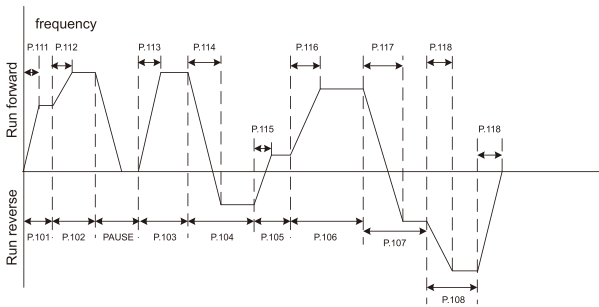

Equipped With Grid Power Frequency Switching Mechanism

- It provides automatic switch between the grid power and frequency conversion.
- If the motor is running at rated frequency, using grid power frequency has a much better efficiency.

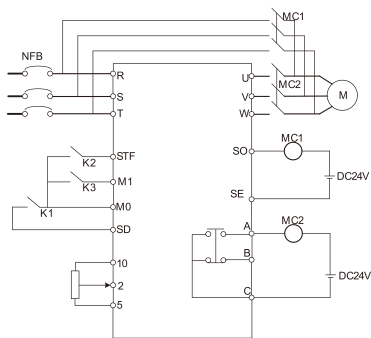

Easy To Install Design

- Din rail design for multiple inverters side by side installation.



- Built-in standard RJ45 port for RS485 communication.
- Screwless terminal blocks designed



- The cooling fan is removable and easy to clean.

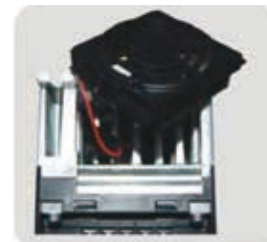

Electric Specifications

220V Series Single-Phase

| Frame | | A | | B | |
|---------------------------|-----------------------------------------|---------------------------------------------------------------|--------------------|------|------|
| Model SS2-021- □□□ K | | 0.4K | 0.75K | 1.5K | 2.2K |
| Applicable Motor Capacity | HP | 0.5 | 1 | 2 | 3 |
| | kW | 0.4 | 0.75 | 1.5 | 2.2 |
| Output | Rated output capacity kVA (Note) | 0.95 | 1.5 | 2.5 | 4.2 |
| | Rated output current A (Note) | 2.7 | 4.5 | 8 | 11 |
| | Overload current rating | 150% 60 seconds; 200% 1 second (inverse time characteristics) | | | |
| | Maximum output voltage | 3 Phase 200~240V AC | | | |
| Power supply | Rated power voltage | Single phase 200~240V 50Hz/ 60Hz | | | |
| | Power voltage permissible fluctuation | Single phase 170~264V 50Hz / 60Hz | | | |
| | Power frequency permissible fluctuation | ±5% | | | |
| | Power source capacity kVA | 1.5 | 2.5 | 3.5 | 6.4 |
| Cooling Method | | Self-cooling | Forced air cooling | | |
| Inverter weight (kg) | | 1.2 | 1.2 | 1.6 | 1.7 |

220V Series Three-Phase

| Frame | | A | | | B | |
|---------------------------|-----------------------------------------|---------------------------------------------------------------|--------------------|-----|-----|------|
| Model SS2-023- □□□ K | | 0.4 | 0.75 | 1.5 | 2.2 | 3.7 |
| Applicable Motor Capacity | HP | 0.5 | 1 | 2 | 3 | 5 |
| | kW | 0.4 | 0.75 | 1.5 | 2.2 | 3.7 |
| Output | Rated output capacity kVA (Note) | 1.2 | 2 | 3.2 | 4.2 | 6.7 |
| | Rated output current A (Note) | 3 | 5 | 8 | 11 | 17.5 |
| | Overload current rating | 150% 60 seconds; 200% 1 second (inverse time characteristics) | | | | |
| | Maximum output voltage | 3 Phase 200~240V AC | | | | |
| Power supply | Rated power voltage | 3 Phase 200~240V 50Hz/60Hz | | | | |
| | Power voltage permissible fluctuation | 3 Phase 170~264V 50Hz/60Hz | | | | |
| | Power frequency permissible fluctuation | ±5% | | | | |
| | Power source capacity kVA | 1.5 | 2.5 | 4.5 | 6.4 | 10 |
| Cooling Method | | Self-cooling | Forced air cooling | | | |
| Inverter weight (kg) | | 1.1 | 1.2 | 1.2 | 1.6 | 1.7 |

440V Series Three-Phase

| Frame | | A | | | B | | |
|---------------------------|-----------------------------------------|---------------------------------------------------------------|--------------|--------------------|-----|------|------|
| Model SS2-043- □□□ K | | 0.4 | 0.75 | 1.5 | 2.2 | 3.7 | 5.5 |
| Applicable Motor Capacity | HP | 0.5 | 1 | 2 | 3 | 5 | 7.5 |
| | kW | 0.4 | 0.75 | 1.5 | 2.2 | 3.7 | 5.5 |
| Output | Rated output capacity kVA (Note) | 1 | 2 | 3 | 4.6 | 6.9 | 9.2 |
| | Rated output current A (Note) | 1.5 | 2.6 | 4.2 | 6 | 9 | 12 |
| | Overload current rating | 150% 60 Seconds; 200% 1 Second (inverse time characteristics) | | | | | |
| | Maximum output voltage | Three-phase 380~480V | | | | | |
| Power supply | Rated power voltage | 3 Phase 380~480V 50Hz / 60Hz | | | | | |
| | Power voltage permissible fluctuation | 323~528V 50Hz/60Hz | | | | | |
| | Power frequency permissible fluctuation | ±5% | | | | | |
| | Power source capacity kVA | 1.5 | 2.5 | 4.5 | 6.9 | 10.4 | 13.8 |
| Cooling Method | | Self-cooling | Self-cooling | Forced air cooling | | | |
| Inverter weight (kg) | | 1.1 | 1.1 | 1.2 | 1.6 | 1.7 | 1.7 |

Note:

The test conditions of rated output current, rated output capacity and inverter power consumption are: the carrier frequency (P.72) is at factory setting value; the inverter output voltage is at 220V/440V; the output frequency is at 60Hz, and the ambient temperature is 50°C.



Common Specifications

| | | | |
|---------------------------------------------------|---------------------------------|---------------------------------------------------------------------------------------------------------------------------------------------------------------------------------------------------------------------------------------|----------------------------------------------------------------------------------------------------------------------------------------------------------------|
| Control Method | | SVPWM control, V/F control, general flux vector control. | |
| Output Frequency Range | | 0.1~599Hz (The starting frequency setting range is between 0 and 60Hz). | |
| Frequency Resolution | Digital setting | If the frequency value is set below 100Hz, the resolution will be 0.01Hz. If the frequency value is set above 100Hz, the resolution will be 0.1Hz. | |
| | Analog setting | When setting the signal DC 0~5V, the resolution will be 1/500; When setting the signal DC 0~10V or 4~20mA, the resolution will be 1/1000. | |
| Output Frequency Accuracy | Digital setting | Maximum target frequency±0.01%. | |
| | Analog setting | Maximum target frequency±0.5%. | |
| Voltage / Frequency output Characteristics | | Base voltage (P.19), base frequency (P.3) can be arbitrarily set. Constant torque model and applicable load model can be selected (P.14). | |
| Starting Torque | | 150% 3Hz, 200% 5Hz: when using the general flux vector control. | |
| Torque Boost | | The torque boost setting range between 0 and 30% (P.0), auto boost, slip compensation. | |
| Acceleration / Deceleration Curve Characteristics | | The resolution (0.01s/0.1s) of acceleration/deceleration time (P.7, P.8) is switched by P.21. The setting range has 0~360s or 0~3600s for selection. And different acceleration/deceleration curve model can be selected by P. 29. | |
| DC Braking | | The DC braking action frequency range between 0 and 120Hz (P.10); the DC braking time is 0~60 Seconds (P.11); and the DC braking voltage is 0~30% (P.12). Linear braking and idling braking selection (P.71). | |
| Stall current protection | | The stalling protection level can be set between 0 and 250% (P. 22). | |
| Target Frequency Setting | | Keypad setting, DC 0~5V signal setting, DC 0~10V signal setting, DC 4~20mA signal setting, Multi-speed stage levels setting, communication setting, pulse frequency setting. | |
| PID Control | | Please refer to P.170~P.183 in Chapter 5. | |
| Multifunction Control Terminals | | Motor starting (STF, STR), the second function (RT), '16-speed operation' (RL, RM, RH, REX), external thermal relay (OH), reset (RES), etc. (can be set by the user (P.80~P.84, P.86) | |
| Multiple Output Terminals | Multi-function output terminals | SO, SE | P.40 |
| | Multi-function output relay | A, B, C | P.85 |
| | Analog output | AM, 5 | |
| Keypad | Running status monitoring | | Output frequency monitoring, output current monitoring, and output voltage monitoring, alarm record |
| | HELP mode | | Alarm history monitoring. |
| | LED indicator (6) | | Run indicator, frequency monitoring indicator, voltage monitoring indicator, current monitoring indicator, mode switching indicator, and PU control indicator. |
| Communication Function | | RS485 | Build-in RS485 communication, RJ-45 connector. |
| Protection Mechanism / Alarm function | | Output short circuit protection, Over-current protection, (+P)/(-N) over-voltage protection, under-voltage protection, motor over heat protection (P.9), IGBT module over-heat protection, communication abnormality protection, etc. | |
| Environmental Condition | Ambient temperature | | -10 ~ +50C (non-freezing), installation side by side -10~ +40°C . |
| | Ambient humidity | | Below 90%Rh (non-condensing) |
| | Storage temperature | | -20 ~ +65°C |
| | Surrounding environment | | Indoor, no corrosive gas, no flammable gas, no flammable dust |
| | Altitude and vibration | | Altitude:below 1000 m, Vibration:below 5.9m/s ² (0.6G). |
| | Enclosure Rating | | IP20 |
| | Pollution level | | 2 |
| Class of protection | | Class 1 | |
| Certification | | CE | |

Wiring Diagram

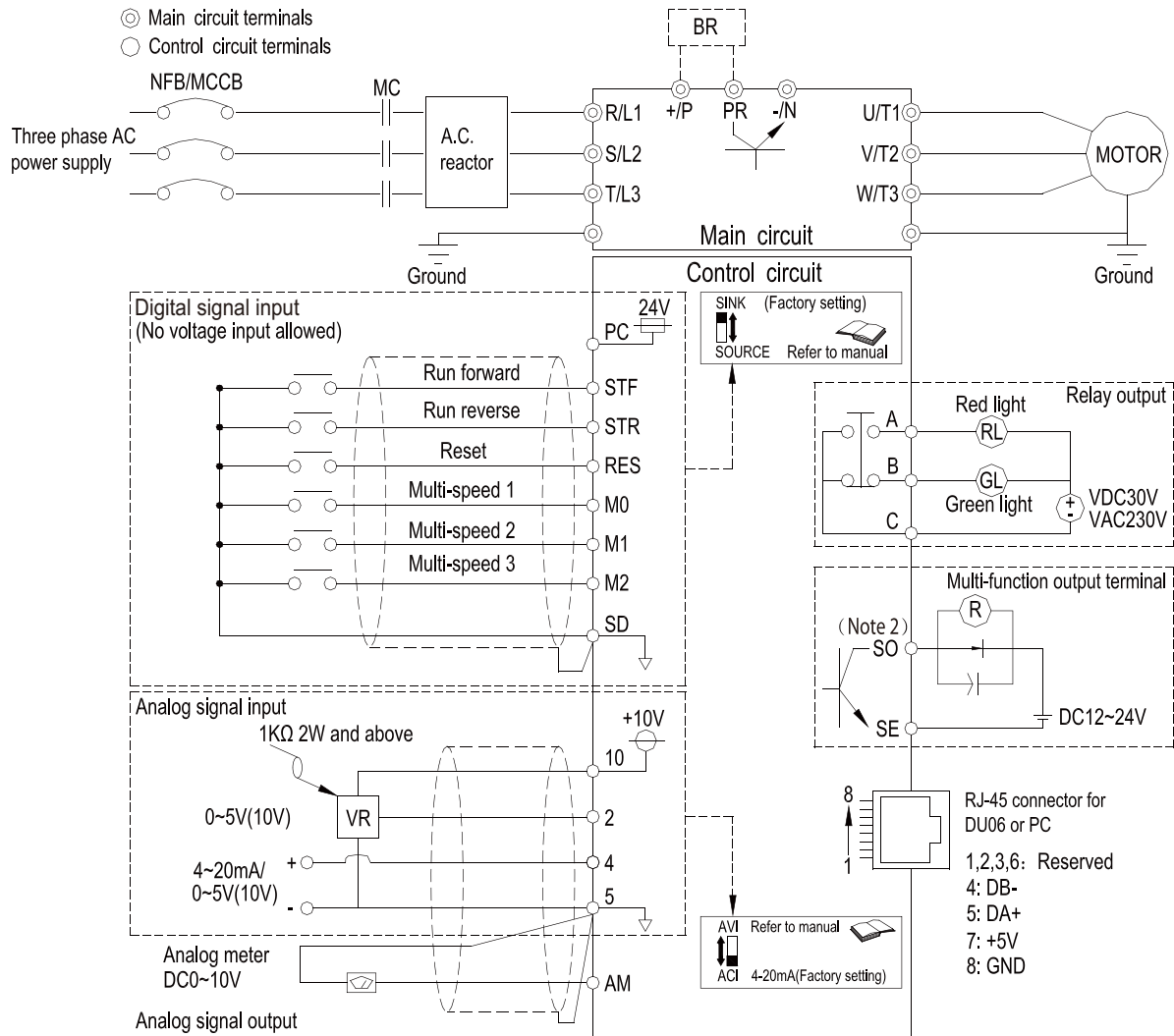

NOTE

1. For the usage of the external thermal relay, please refer to P.80~P.84, P.86 in Chapter 5 (OH) on the manual.
2. Make sure not to short circuit the PC and SD.
3. In the above figure, dotted line area, please refer to 3.5.7 on the manual.
4. The SO terminal can select to FM or 10X function, please refer to P.64, P.74.
5. For single-phase series inverters, there is no T/L3 terminal, and the corresponding wiring(dotted line) doesn't need to be connected.



SS2

Dimensions

Unit: mm

Frame A

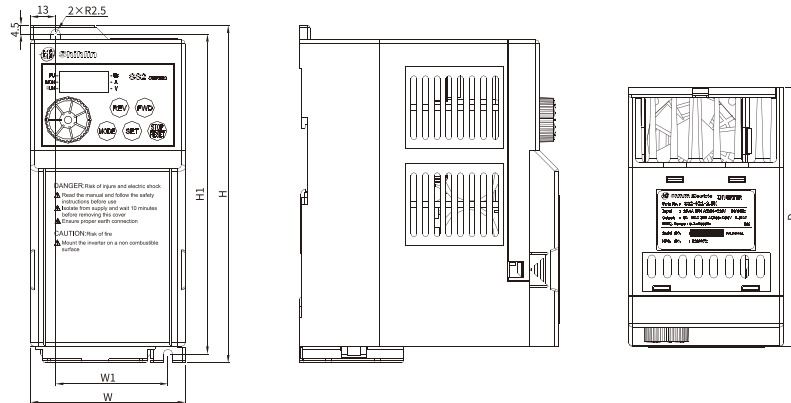

Frame A

| Model | H (mm) | H1 (mm) | W (mm) | W1 (mm) | D (mm) |
|---------------|--------|---------|--------|---------|--------|
| SS2-021-0.4K | 174 | 165 | 80 | 58 | 134 |
| SS2-021-0.75K | | | | | |
| SS2-023-0.4K | | | | | |
| SS2-023-0.75K | | | | | |
| SS2-023-1.5K | | | | | |
| SS2-043-0.4K | | | | | |
| SS2-043-0.75K | | | | | |
| SS2-043-1.5K | | | | | |

Frame B

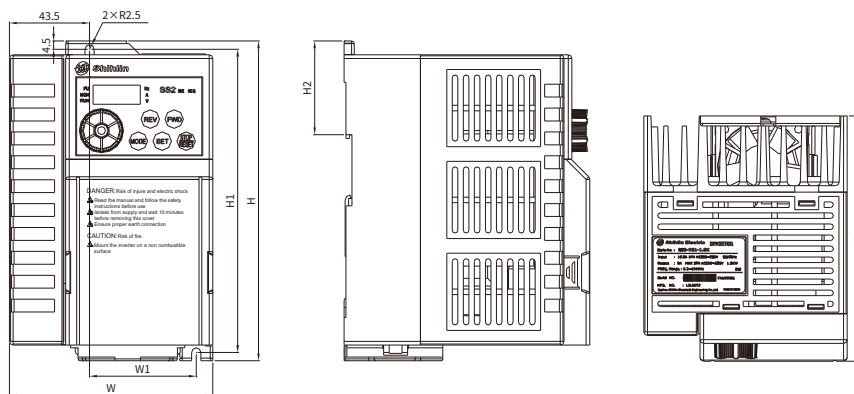

Frame B

| Model | H (mm) | H1 (mm) | W (mm) | W1 (mm) | D (mm) |
|--------------|--------|---------|--------|---------|--------|
| SS2-021-1.5K | 174 | 165 | 110.5 | 58 | 134 |
| SS2-021-2.2K | | | | | |
| SS2-023-2.2K | | | | | |
| SS2-023-3.7K | | | | | |
| SS2-043-2.2K | | | | | |
| SS2-043-3.7K | | | | | |
| SS2-043-5.5K | | | | | |

SE3 series

High Speed Closed Loop/
Communication Inverter

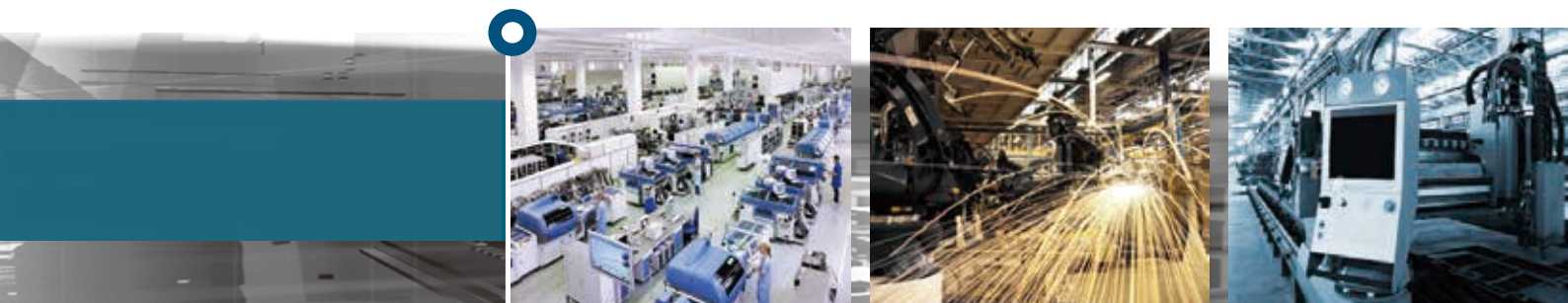

Power Range

| Model | kW (HP) | 0.4 (0.5) | 0.75 (1) | 1.5 (2) | 2.2 (3) | 3.7 (5) | 5.5 (7.5) | 7.5 (10) | 11 (15) | 15 (20) | 18.5 (25) | 22 (30) | |
|-------|---------|--------------|----------|---------|---------|---------|-----------|----------|---------|---------|-----------|---------|--|
| SE3 | 021 | 1 phase 220V | | | | | | | | | | | |
| | 023 | 3 phase 220V | | | | | | | | | | | |
| | 043 | 3 phase 440V | | | | | | | | | | | |

Product Features

High Performance Vector Control Technology

- High starting torque: Sensorless vector control (SVC) 200% 0.5Hz, and closed-loop vector control (FOC + PG) 180% 0Hz.

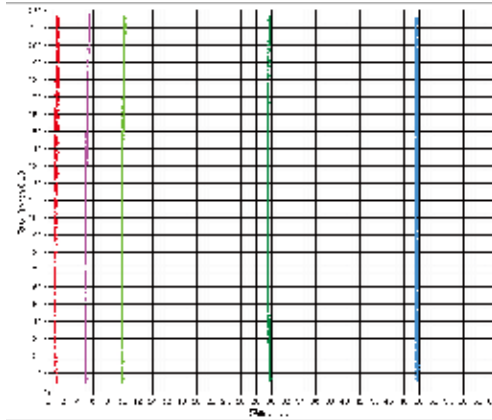

High Performance Synchronous Motor Control Technology

- Support induction motor (IM) and synchronous motor (IPM and SPM) control.



Support Multiple High-speed Bus Connections

- Optional high-speed communications: CANopen, Profibus, DeviceNet, EtherCAT, MODBUS TCP.



Product Features

Multiple Control Modes for Various Applications

- Position / Speed / Torque / Tension control mode.
- Combination mode (e.g. speed+torque) can be achieved via I/O switch.
- Advanced position control functions: Homing commands, zero speed, Pr/Pt mode(with optional PG cards).

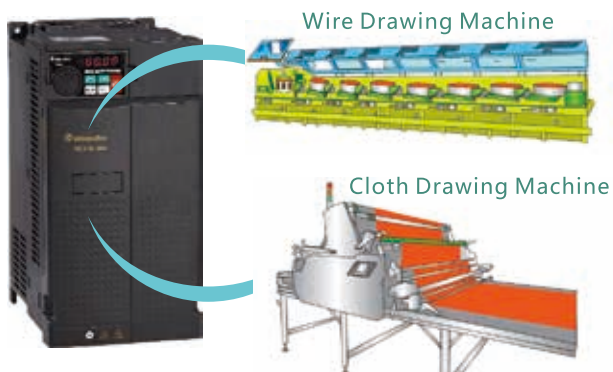

Low-noise Carrier Wave Control (Soft-PWM)

- Motor noise is controlled so that the metallic sound is transformed into a more pleasing buzz.
- Low noise operations to reduce the interference exerted upon external radio frequencies.

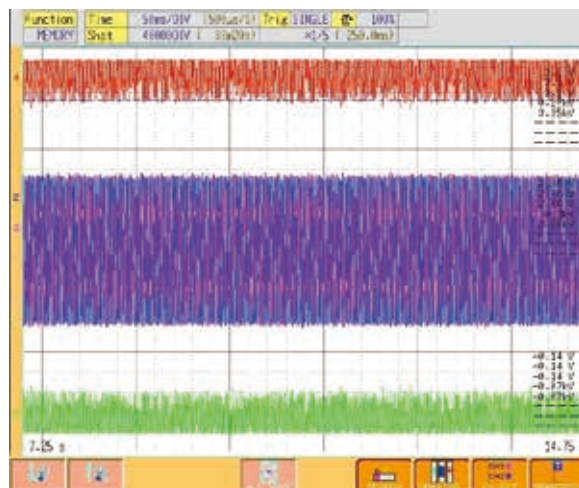

Excellent Overload Endurance

- With a current overload capability of 150% for 60 seconds and 200% for 3 seconds, the setting is suitable for handling large sudden load changes applications such as tooling machinery.

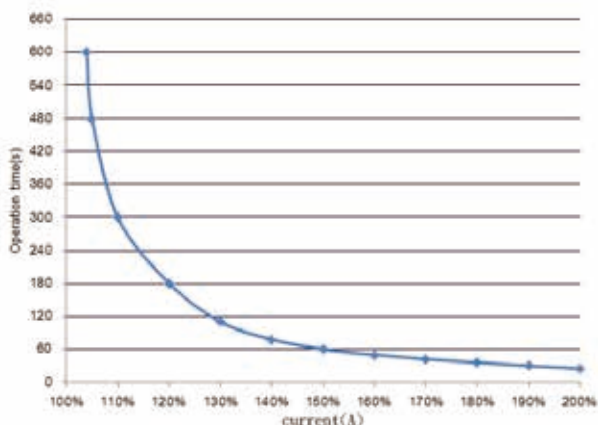

Built-in RFI filter

- Reduce electromagnetic interference.

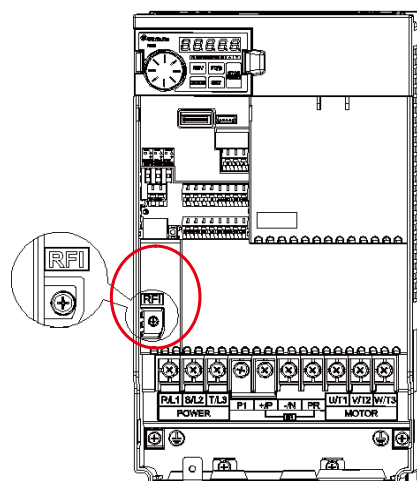

Product Features

Isolated Air Duct

- The air duct of the fan is sealed and isolates the heat dissipation system from the electrical parts, so that the dust won't easily enter the drive through the fan.

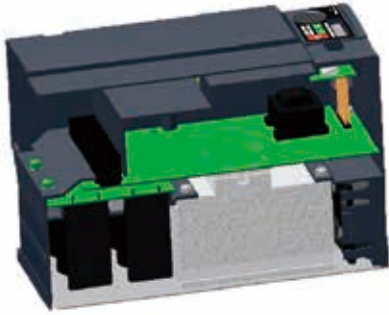

Complete Protection Functions

- Phase failure protection, overvoltage protection, overcurrent protection, undervoltage protection, output short-circuit protection, output to ground protection, motor overheat protection, IGBT module overheat protection, communication abnormality protection.

LED Digital Keypad

- 5-digit 7-segment display
- Optimized operation JOG Dial



Quick Connect to External Keypad and Easy Wiring

- Standard RJ45 network interface and DA+ DB- terminals are equipped for multi-machine communication.

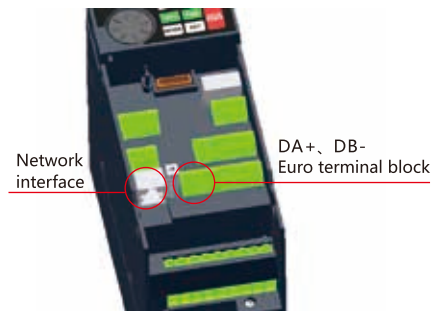

12 Sets of Alarm Records

- Complete alarm system for recording the output frequency, output current, output voltage, accumulated rate of temperature increase, PN voltage, total operation time, operational status, alarm trigger time. A total of 12 alarm code, 12 groups of alarm code.

| | | | | | |
|-------|-------|--------------------|------|------|-----|
| P.288 | 06-40 | Alarm code query | 0~12 | 0 | 176 |
| P.289 | 06-41 | Alarm code display | Read | Read | 176 |
| P.290 | 06-42 | Alarm code query | 0~10 | 0 | 176 |
| P.291 | 06-43 | Alarm code display | Read | Read | 176 |

Built-in PLC Functions

- Provide PLC programming software, easy for editing.
- Applicable for programming small number of points, and support multiple functions.



Product Features

Grouping Parameters - Easy Setup

| Group | Parameter Number | Name | Setting Range | Default |
|-------|------------------|-----------------------------------------------------------------|----------------|---------|
| 02-10 | P.60 | Terminal 2-5 filter time | 0 ~ 2000ms | 30ms |
| 02-11 | P.139 | Terminal 2-5 voltage signal bias rate | -100.0%~100.0% | 0.0% |
| 02-12 | P.192 | Terminal 2-5 minimum input positive voltage | 0 ~ 10.00V | 0.00V |
| 02-13 | P.193 | Terminal 2-5 maximum input positive voltage | 0 ~ 10.00V | 10.00V |
| 02-14 | P.194 | Percentage corresponds to terminal 2-5 minimum positive voltage | -100%~100% | 0.0% |
| 02-15 | P.195 | Percentage corresponds to terminal 2-5 maximum positive voltage | -100% ~100% | 100% |

SE3 series: Similar functions are grouped into same sectors instead of sequence numbers.

Easy Maintenance

- The fan is designed on the top to effectively reduce the impact of falling dust, and the terminal wiring will not affect the maintenance of the fan.



Model Identification

SE3

043

0.75K

XY

| Series | Voltage level | Capacity | Version |
|------------|-----------------------------------------------------------------------------|----------|------------------------------------------------------------------------------|
| SE3 series | 043 : three phase 440V 023 : three phase 220V 021 : single phase 220V | 0.75kW | None : General model -xy : Customized or specialized or region difference |



Electrical Specifications

220V series one-phase/three-phase

| Frame | | A | | B | | |
|-------------------------|-----------------------------------------|--------------------------------------------------------------|---------------------------------------------------------------|--------------------|------|------|
| Model SE3-021- □ -xy | | 0.4K | 0.75K | 1.5K | 2.2K | |
| Output | HD | Rated output capacity (kVA) | 1 | 1.5 | 3.2 | 4.2 |
| | | Rated output current (A) | 2.7 | 4.5 | 8 | 11 |
| | | Applicable motor capacity (HP) | 0.5 | 1 | 2 | 3 |
| | | Applicable motor capacity(kW) | 0.4 | 0.75 | 1.5 | 2.2 |
| | | Overload current rating | 150% 60 seconds 200% 3 seconds (inverse time characteristics) | | | |
| | Carrier frequency (kHz) | 1~15kHz | | | | |
| | ND | Rated output capacity (kVA) | 1.2 | 2 | 3.4 | 4.8 |
| | | Rated output current (A) | 3 | 5 | 8.5 | 12.5 |
| | | Applicable motor capacity (HP) | 0.5 | 1 | 2 | 3 |
| | | Applicable motor capacity (kW) | 0.4 | 0.75 | 1.5 | 2.2 |
| Overload current rating | | 120% 60 seconds 150% 3seconds (inverse time characteristics) | | | | |
| Carrier frequency (kHz) | 1~15kHz | | | | | |
| Maximum output voltage | | Three-phase 200-240V | | | | |
| Power supply | Rated power voltage | | One-phase 200-240V 50Hz / 60Hz | | | |
| | Power voltage permissible fluctuation | | One -phase 170-264V 50Hz / 60Hz | | | |
| | Power frequency permissible fluctuation | | ±5% | | | |
| | Power source capacity (kVA) | | 1.5 | 2.5 | 4.5 | 6.9 |
| | Rated input current(A) (Note1) | HD | 5.9 | 9.7 | 14.8 | 23.1 |
| ND | | 6.7 | 10.5 | 17.9 | 26.3 | |
| Cooling method | | Self cooling | | Forced air cooling | | |
| Weight(kg) | | 1.0 | 1.0 | 1.5 | 1.5 | |

| Frame | | A | | | B | | C | | D | | |
|-------------------------|-----------------------------------------|---------------------------------------------------------------|--------------------------------------------------------------|------|------|------|------|------|------|------|------|
| Model SE3-023- □ -xy | | 0.4K | 0.75K | 1.5K | 2.2K | 3.7K | 5.5K | 7.5K | 11K | 15K | |
| Output | HD | Rated output capacity (kVA) | 1.2 | 2 | 3.2 | 4.2 | 6.7 | 9.5 | 12.5 | 18.3 | 24.7 |
| | | Rated output current (A) | 3 | 5 | 8 | 11 | 17.5 | 25 | 33 | 49 | 65 |
| | | Applicable motor capacity (HP) | 0.5 | 1 | 2 | 3 | 5 | 7.5 | 10 | 15 | 20 |
| | | Applicable motor capacity(kW) | 0.4 | 0.75 | 1.5 | 2.2 | 3.7 | 5.5 | 7.5 | 11 | 15 |
| | | Overload current rating | 150% 60 seconds 200% 3seconds (inverse time characteristics) | | | | | | | | |
| | Carrier frequency (kHz) | 1~15kHz | | | | | | | | | |
| | ND | Rated output capacity (kVA) | 1.3 | 2.1 | 3.4 | 4.8 | 7.4 | 10.3 | 13.7 | 19.4 | 26.3 |
| | | Rated output current (A) | 3.2 | 5.5 | 8.5 | 12.5 | 19.5 | 27 | 36 | 51 | 69 |
| | | Applicable motor capacity (HP) | 0.5 | 1 | 2 | 3 | 5 | 7.5 | 10 | 15 | 20 |
| | | Applicable motor capacity (kW) | 0.4 | 0.75 | 1.5 | 2.2 | 3.7 | 5.5 | 7.5 | 11 | 15 |
| Overload current rating | | 120% 60 seconds 150% 3 seconds (inverse time characteristics) | | | | | | | | | |
| Carrier frequency (kHz) | 1~15kHz | | | | | | | | | | |
| Maximum output voltage | | Three-phase 200-240V | | | | | | | | | |
| Power supply | Rated power voltage | | Three-phase 200-240V 50Hz /60Hz | | | | | | | | |
| | Power voltage permissible fluctuation | | Three-phase 170-264V 50Hz/ 60Hz | | | | | | | | |
| | Power frequency permissible fluctuation | | ±5% | | | | | | | | |
| | Power source capacity (kVA) | | 1.5 | 2.5 | 4.5 | 6.4 | 10 | 12 | 17 | 20 | 28 |
| | Rated input current(A) (Note1) | HD | 3.5 | 6.0 | 9.6 | 13.2 | 20.4 | 30 | 39.6 | 58.8 | 78 |
| ND | | 3.8 | 6.6 | 10.2 | 15 | 23.4 | 32.4 | 43.2 | 61.2 | 82.8 | |
| Cooling method | | Forced air cooling | | | | | | | | | |
| Weight(kg) | | 1.0 | 1.0 | 1.0 | 1.5 | 1.5 | 4.0 | 4.1 | 5.7 | 5.8 | |

Note1:

The value of rated input current is not only affected by the power transformer, input reactor and wiring conditions but also fluctuates with the impedance on the power side.

Note:

The test conditions of rated output current, rated output capacity and inverter power consumption are:the carrier frequency (P.72) is at the set value; the inverter output voltage is at 220V; the output frequency is at 60Hz, and the ambient temperature is 40°C.

Electrical Specifications

440V series three-phase

| Frame | | A | | | B | | C | | | D | | | |
|-----------------------------------------|-------------------------|------------------------------------------------|---------------------------------------------------------------|--------------------|------|------|------|------|------|------|-------|------|------|
| Model SE3-043-□-xy | | 0.4K | 0.75K | 1.5K | 2.2K | 3.7K | 5.5K | 7.5K | 11K | 15K | 18.5K | 22K | |
| Output | HD | Rated output capacity (kVA) | 1 | 2 | 3 | 4.6 | 6.9 | 10 | 14 | 18 | 25 | 29 | 34 |
| | | Rated output current (A) | 1.5 | 2.7 | 4.2 | 6 | 9 | 12 | 17 | 24 | 32 | 38 | 45 |
| | | Applicable motor capacity (HP) | 0.5 | 1 | 2 | 3 | 5 | 7.5 | 10 | 15 | 20 | 25 | 30 |
| | | Applicable motor capacity(kW) | 0.4 | 0.75 | 1.5 | 2.2 | 3.7 | 5.5 | 7.5 | 11 | 15 | 18.5 | 22 |
| | | Overload current rating | 150% 60 seconds 200% 3 seconds (inverse time characteristics) | | | | | | | | | | |
| | Carrier frequency (kHz) | 1~15kHz | | | | | | | | | | | |
| | ND | Rated output capacity (kVA) | 1.4 | 2.3 | 3.5 | 5 | 8 | 12 | 15.6 | 21.3 | 27.4 | 31.6 | 37.3 |
| | | Rated output current (A) | 1.8 | 3 | 4.6 | 6.5 | 10.5 | 15.7 | 20.5 | 28 | 36 | 41.5 | 49 |
| | | Applicable motor capacity (HP) | 0.5 | 1 | 2 | 3 | 5 | 7.5 | 10 | 15 | 20 | 25 | 30 |
| | | Applicable motor capacity (kW) | 0.4 | 0.75 | 1.5 | 2.2 | 3.7 | 5.5 | 7.5 | 11 | 15 | 18.5 | 22 |
| Overload current rating | | 120% 60 seconds (inverse time characteristics) | | | | | | | | | | | |
| Carrier frequency (kHz) | 1~15kHz | | | | | | | | | | | | |
| Maximum output voltage | | Three-phase 380-480V | | | | | | | | | | | |
| Rated power voltage | | Three-phase 380-480V 50Hz / 60Hz | | | | | | | | | | | |
| Power voltage permissible fluctuation | | Three-phase 323-528V 50Hz / 60Hz | | | | | | | | | | | |
| Power frequency permissible fluctuation | | ±5% | | | | | | | | | | | |
| Power source capacity (kVA) | | 1.5 | 2.5 | 4.5 | 6.9 | 10.4 | 11.5 | 16 | 20 | 27 | 32 | 41 | |
| Rated input current(A) (Note1) | HD | 2.1 | 3.7 | 5.8 | 6.5 | 9.9 | 14.3 | 18.7 | 27.5 | 35.2 | 41.8 | 48.5 | |
| | ND | 2.5 | 4.2 | 6.4 | 7.2 | 11.6 | 17.3 | 22.6 | 30.8 | 39.6 | 47.7 | 53.9 | |
| Cooling method | | Self cooling | | Forced air cooling | | | | | | | | | |
| Weight(kg) | | 1.0 | 1.0 | 1.0 | 1.5 | 1.5 | 3.9 | 4.0 | 4.0 | 5.7 | 5.8 | 5.8 | |

Note1:

The value of rated input current is not only affected by the power transformer, input reactor and wiring conditions but also fluctuates with the impedance on the power side.

Note:

The test conditions of rated output current, rated output capacity and inverter power consumption are:the carrier frequency (P.72) is at the set value; the inverter output voltage is at 220V; the output frequency is at 60Hz, and the ambient temperature is 40°C.



SE3

Common Specifications

| | | |
|---------------------------------------------------|---------------------------------------|--------------------------------------------------------------------------------------------------------------------------------------------------------------------------------------------------------------------------------------------------------------------------------------------------|
| Control method | | SVPWM control, V/F control, close-loop V/F control (VF+PG), general flux vector control, sensorless vector control (SVC), close-loop vector control (FOC+PG), torque control (TQC+PG). |
| Output frequency range | | 0-599Hz(*1) |
| Frequency setting resolution | Digital setting | The resolution is 0.01Hz. |
| | Analog setting | 0.01Hz/60Hz(terminal 2: -10 ~ +10V / 13bit) 0.15Hz/60Hz(terminal 2: 0 ~ ±10V / 12bit) 0.03Hz/60Hz(terminal 2: 0 ~ 5V / 11bit) 0.06Hz/60Hz(terminal 4: 0~10V, 4-20mA / 12bit) 0.12Hz/60Hz(terminal 4: 0 ~ 5V / 11bit) |
| Output frequency accuracy | Digital setting | Maximum target frequency±0.01%. |
| | Analog setting | Maximum target frequency±0.1%. |
| Speed control range | | IM: When SVC, 1:200; when FOC+PG, 1:1000. PM: When SVC, 1:20; when FOC+PG, 1:1000. |
| Start torque | | 200% 0.5 Hz |
| V/F characteristics | | Constant torque curve, variable torque curve, five-point curve, VF separation |
| Acceleration / deceleration curve characteristics | | Linear acceleration / deceleration curve, S shape acceleration /deceleration curve |
| Drive motor | | Induction motor(IM), permanent magnet motor(SPM, IPM) |
| Stalling protection | | The stalling protection level can be set to 0~250% |
| Target frequency setting | | Keypad setting, DC 0~5V / 10V signal, DC -10~+10V signal, DC 4~20 mA signal, multiple speed stage level setting, communication setting, HDI setting. |
| PID control | | Please refer to parameter description |
| Built-in simple PLC | | Supports 21 basic instructions and 14 application instructions, including PC editing software; |
| Keypad | Operation monitoring | Output frequency, output current, output voltage, PN voltage, output torque, electronic thermal accumulation rate, temperature rising accumulation rate, output power, Analog value input signal, digital input and output terminal status... ; alarm signal and alarm history 12 groups at most |
| | LED indicator (7) | Forward rotation indicator, reverse rotation indicator, frequency monitoring indicator, mode switch indicator ,PU control indicator, PLC indicator and run indicator |
| Communication function | | Built-in Shihlin / Modbus communication protocol, can select MODBUS TCP, CANopen, Profibus, DeviceNet, EtherCAT card |
| Protection mechanism / alarm function | | Output short circuit protection, Over-current protection, over-voltage protection, under-voltage protection, motor over-heat protection, IGBT module over-heat protection, communication abnormality protection, |
| Environment | Ambient temperature | HD : -10 ~ +50°C (non-freezing) · ND : -10 ~ +40°C (non-freezing), please refer to 3.4.2 Class of protection and operation temperature for details. |
| | Ambient humidity | Below 90%Rh (non-condensing). |
| | Storage temperature | -20 ~ +65°C . |
| | Surrounding environment | Indoor, no corrosive gas, no flammable gas, no flammable dust. |
| | Altitude | Altitude below 2000 m, when altitude is above 1000 m, derate the rated current 2% per 100 m |
| | Vibration | Vibration below 5.9m/s ² (0.6G). |
| | Grade of protection | IP20 |
| | The degree of environmental pollution | 2 |
| Class of protection | | Class I |
| International certification | | CE |

*1: SE3 series can be customized up to 1500Hz. Please contact us if necessary.

Wiring Diagram

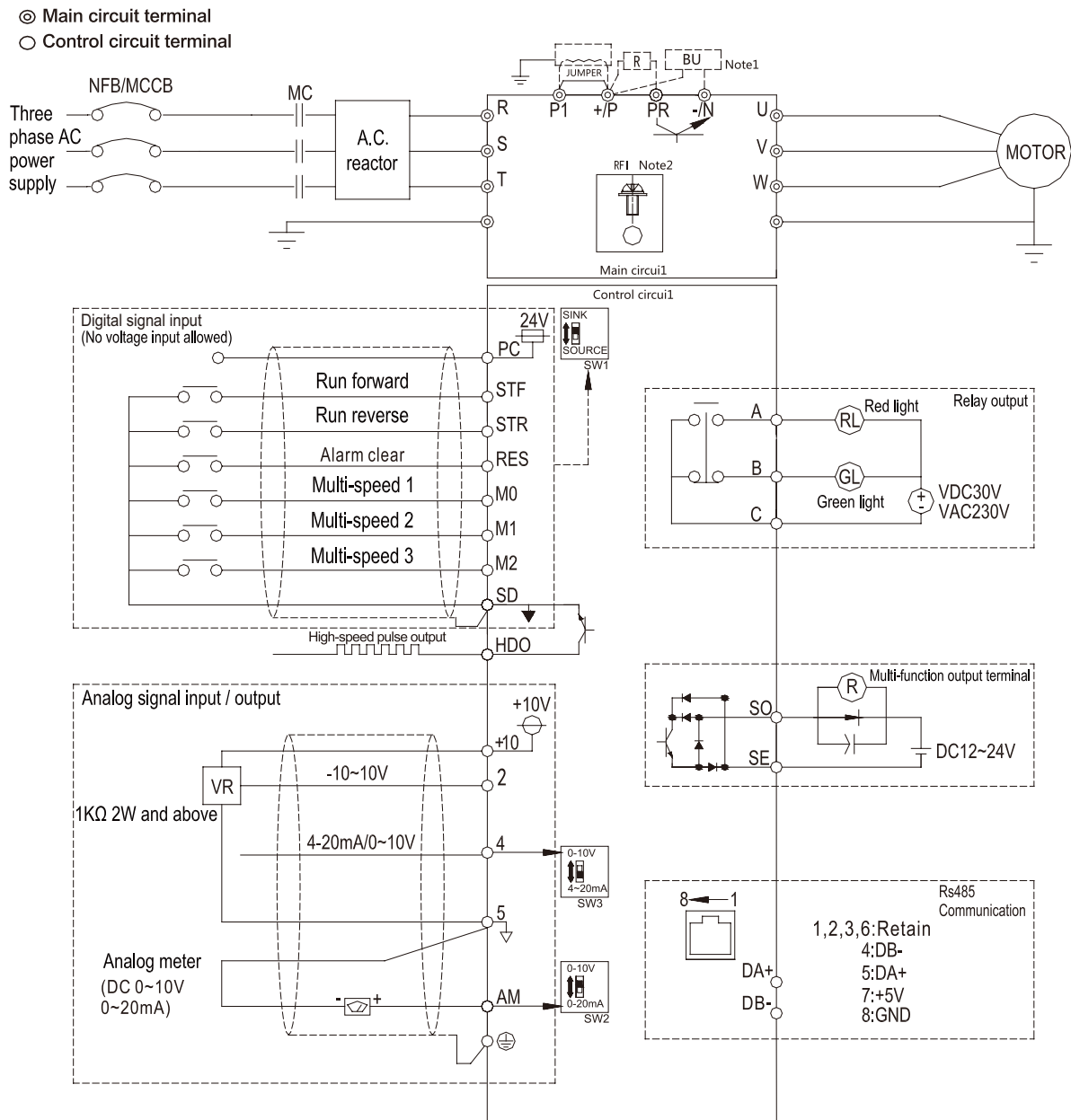

NOTE

1. Make sure 10, SD, SE, 5 and PC are not shorted to each other.
2. The DC reactor between +P and P1 is optional, please short +P and P1 when DC reactor is not used.
3. All series have built-in braking unit. Please connect braking resistor between +P and PR.
4. All series have built-in RFI filter to suppress electromagnetic interference. In order to comply with CE regulations, please refer to relevant instructions in the manual for installation.

Dimensions

Unit: mm

Frame A

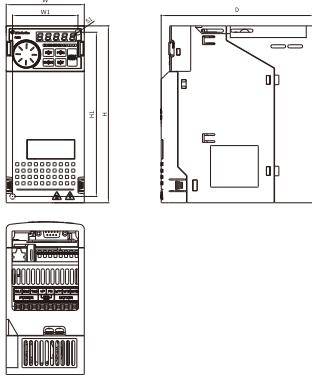

Frame A

| Model type | W (mm) | W1 (mm) | H (mm) | H1 (mm) | D (mm) | S1 (mm) |
|-------------------|--------|---------|--------|---------|--------|---------|
| SE3-043-0.4~1.5K | 74.0 | 62.0 | 167.0 | 155.0 | 144.0 | 5.2 |
| SE3-023-0.4~1.5K | | | | | | |
| SE3-021-0.4~0.75K | | | | | | |

Frame B

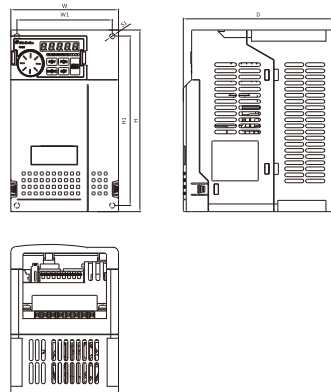

Frame B

| Model type | W (mm) | W1 (mm) | H (mm) | H1 (mm) | D (mm) | S1 (mm) |
|------------------|--------|---------|--------|---------|--------|---------|
| SE3-043-2.2~3.7K | 105.0 | 93.0 | 178.0 | 166.0 | 146.0 | 5.2 |
| SE3-023-2.2~3.7K | | | | | | |
| SE3-021-1.5~2.2K | | | | | | |

Frame C

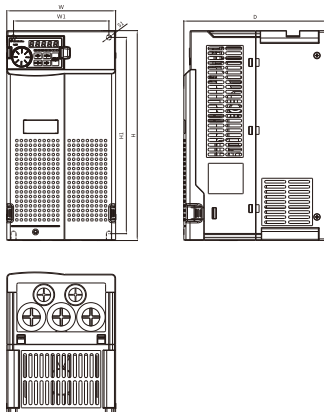

Frame C

| Model type | W (mm) | W1 (mm) | H (mm) | H1 (mm) | D (mm) | S1 (mm) |
|------------------|--------|---------|--------|---------|--------|---------|
| SE3-043-5.5~11K | 141.0 | 123.6 | 270.0 | 252.6 | 185.0 | 6.5 |
| SE3-023-5.5~7.5K | | | | | | |

Frame D

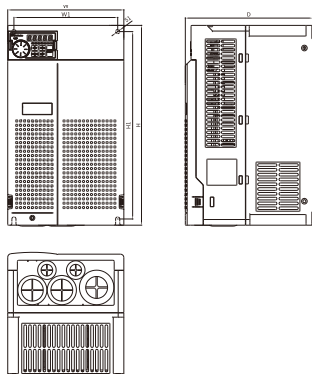

Frame D

| Model type | W (mm) | W1 (mm) | H (mm) | H1 (mm) | D (mm) | S1 (mm) |
|----------------|--------|---------|--------|---------|--------|---------|
| SE3-043-15~22K | 175.0 | 156.4 | 300.0 | 281.4 | 191.8 | 6.2 |
| SE3-023-11~15K | | | | | | |

SF3 series

Communication
Vector Control Inverter

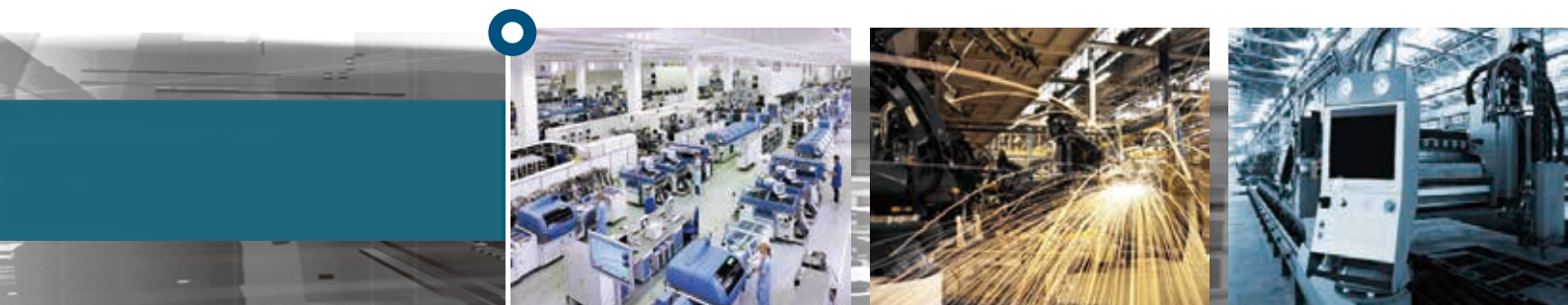

Product Range

| Model | | kW (HP) | 3.7 (5) | 5.5 (7.5) | 7.5 (10) | 11 (15) | 15 (20) | 18.5 (25) | 22 (30) | 30 (40) | 37 (50) | 45 (60) | 55 (75) | 75 (100) | 90 (120) | 110 (150) | 132 (175) | 160 (215) | 185 (250) | 220 (300) | 250 (335) | 280 (375) | 315 (420) | 355 (475) |
|-------|---------|--------------|---------|-----------|----------|---------|---------|-----------|---------|---------|---------|---------|---------|----------|----------|-----------|-----------|-----------|-----------|-----------|-----------|-----------|-----------|-----------|
| SF3 | SF3-043 | 3 phase 440V | 150%60s | / | | | | | | | | | | | | | | | | | | | | |
| | | | 200%3s | | | | | | | | | | | | | | | | | | | | | |
| | | | 120%60s | | | | | | | | | | | | | | | | | | | | | |

Model Identification

SF3 **043** **5.5K/3.7KG** **XY**

| Series | Voltage level | Capacity | Version |
|------------|------------------------|----------------------|------------------------------------------------------------------------------|
| SF3 series | 043 : three phase 440V | ND:5.5kW HD:3.7kW | None : General model -xy : Customized or specialized or region difference |

Product Features

Multi-Pump Control

- Multi-Pump Control (with EB308R), with multiple relays to support pump control. Controlling maximum of 7 pumps at the same time for 1 inverter.

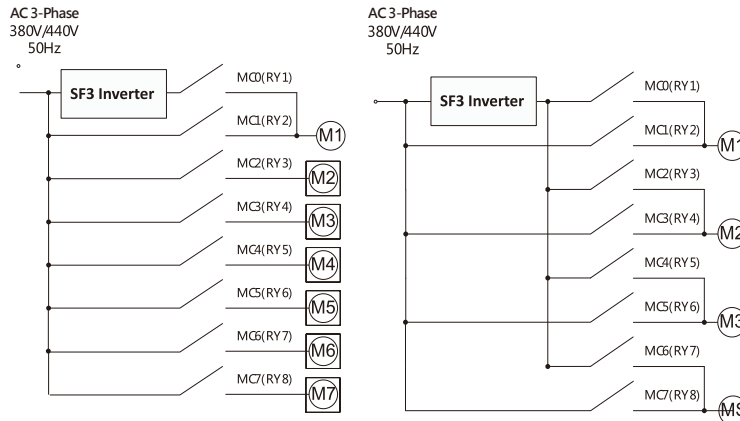

PC Communication Software

- This provides remote control of multiple inverters for parameters setup, copy and monitoring.

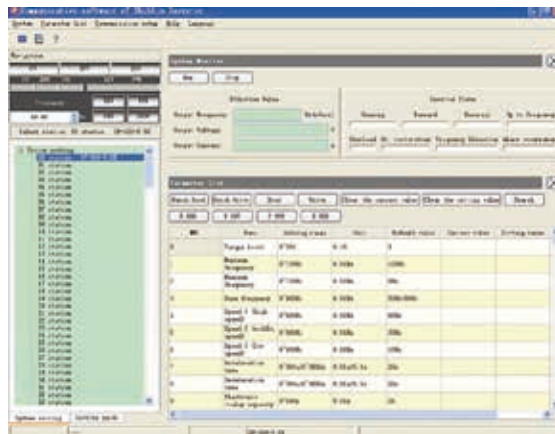

Product

1. Isolated Air Channel

- Ventilation (air flow path) is isolated from the surface of thermal dissipation units and electrical parts. Dust will not be able to infiltrate the interior of the inverter through the fans.

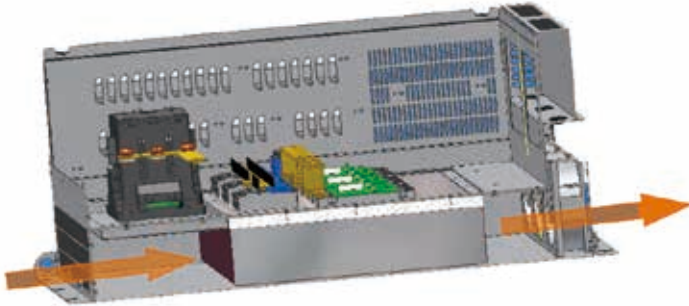

Note: Even though the cooling duct is complete isolated, but if the inverter is installed at the environment where lots of dust or oil gas with out protection, the dust will still pass into inverter.

2. Enhanced PCB Coating

- Protect drive and ensure its operation safety and stability.
- Compliance with international standards IEC 60721-3-3 class 3C2.



- Moisture proof
- Corrosion proof
- Dust proof

3. Terminal Block for Quick Wiring

- Standard RJ45 internet connection with DA+, DB- Euroblock, easy connection for multi-machine communication.
- Support maximum 100kHz pulse input(HDI) and output(HDI) signal.



Quick switch for application needs

| | | | | |
|-----------------|-----------------|-----------------|-----------------|-----------------|
| 0-10V 4-20mA | 4-20mA 0-10V | 0-10V 0-20mA | 0-10V 0-20mA | SINK DEFAULT |
| SW1 | SW2 | SW3 | SW4 | SW5 |





SF3

Features

4. LCD Operation Interface

- Support 2 display styles.
- Able to simultaneously display 6 sets of operational data.
- Calendar support.
- Offer both English and Chinese language interfaces.
- Capable of storing 3 sets of parameters.
- Support shuttle settings.



English display interface

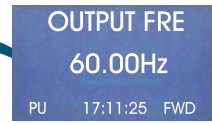

5. Through-the-Wall Installation Support Provided for the Entire Series

- Improve heat dissipation, reduce heat generation within the cabinet, and improve protection for the cabinet contents.

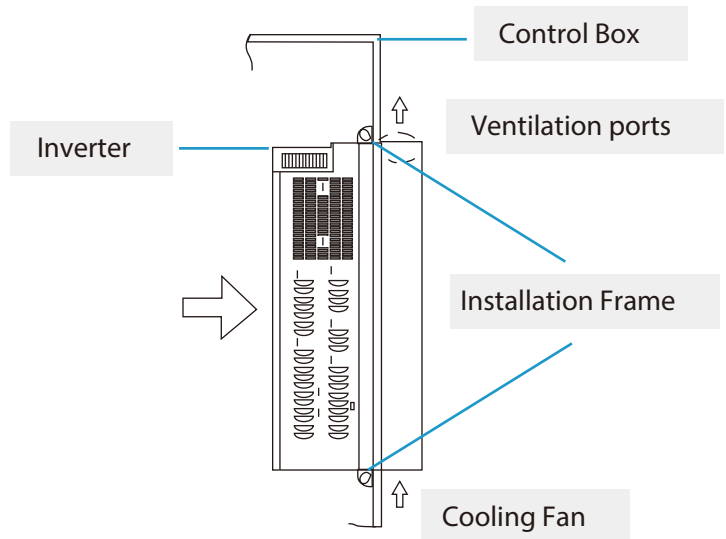

7. Fire Mode

- The fire mode can be activated automatically when a building fire occurs to achieve the best smoke extraction effect and protect people's lives.

| Parameter | Name | Setting range |
|-----------------|-------------------------------------|----------------|
| 06-84 P.1040 | Fire mode | XXX0~1XXX |
| 06-85 P.1041 | Fire mode frequency | 0~650Hz |
| 06-86 P.1042 | Fire mode delay bypass | 0.0~6000.0s |
| 06-87 P.1043 | Fire mode PID target | 0~08-43(P.251) |
| 06-88 P.1044 | Fire mode cumulate times | Read only |
| 06-89 P.1045 | Total of reset in fire mode | 0~200 |
| | | 99999 |
| 06-90 P.1046 | Waiting time for reset in fire mode | 0.0~600.0s |
| | | 99999 |

6. Built-in RFI Filter

- Reduce electromagnetic interference.

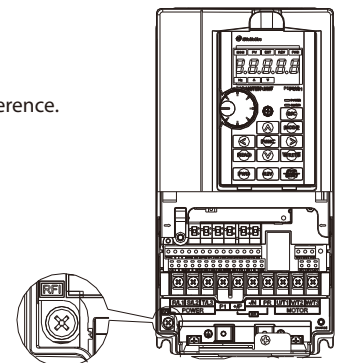

Electrical Specifications

440V three-phase

| Frame | | A | | B | | C | | D | | | | | | |
|------------------------------------------------|--------------------------------|------------------------------------------------|------------------------------------------------|--------|-------|---------|---------|---------|-------|-------|-------|-------|-------|-----|
| Model SF3-043- □ K □ KG | | 5.5/3.7 | 7.5/5.5 | 11/7.5 | 15/11 | 18.5/15 | 22/18.5 | 30/22 | 37/30 | 45/37 | 55/45 | 75/55 | 90/75 | |
| Output | ND | Rated output capacity (kVA) | 10 | 14 | 18 | 25 | 29 | 34 | 46 | 56 | 69 | 84 | 114 | 137 |
| | | Rated output current (A) | 13 | 18 | 24 | 32 | 38 | 45 | 60 | 73 | 91 | 110 | 150 | 180 |
| | | Applicable motor capacity (HP) | 7.5 | 10 | 15 | 20 | 25 | 30 | 40 | 50 | 60 | 75 | 100 | 120 |
| | | Applicable motor capacity(kW) | 5.5 | 7.5 | 11 | 15 | 18.5 | 22 | 30 | 37 | 45 | 55 | 75 | 90 |
| | | Overload current rating | 120% 60 seconds (inverse time characteristics) | | | | | | | | | | | |
| | Carrier frequency (kHz) | 1~15kHz | | | | | | 1~10kHz | | | | | | |
| | HD | Rated output capacity (kVA) | 6.9 | 10 | 14 | 18 | 25 | 29 | 34 | 46 | 56 | 69 | 84 | 114 |
| | | Rated output current (A) | 9 | 13 | 18 | 24 | 32 | 38 | 45 | 60 | 73 | 91 | 110 | 150 |
| | | Applicable motor capacity (HP) | 5 | 7.5 | 10 | 15 | 20 | 25 | 30 | 40 | 50 | 60 | 75 | 100 |
| | | Applicable motor capacity (kW) | 3.7 | 5.5 | 7.5 | 11 | 15 | 18.5 | 22 | 30 | 37 | 45 | 55 | 75 |
| Overload current rating | | 150% 60 seconds (inverse time characteristics) | | | | | | | | | | | | |
| Carrier frequency (kHz) | 1~15kHz | | | | | | | | | | | | | |
| Maximum output voltage | Three-phase 380-480V | | | | | | | | | | | | | |
| Rated power voltage | Three-phase 380-480V 50Hz/60Hz | | | | | | | | | | | | | |
| Allowable fluctuating range of power voltage | Three-phase 323-528V 50Hz/60Hz | | | | | | | | | | | | | |
| Allowable fluctuating range of power frequency | ±5% | | | | | | | | | | | | | |
| Power source capacity (kVA) | 10.4 | 11.5 | 16 | 20 | 27 | 32 | 41 | 52 | 65 | 79 | 100 | 110 | | |
| Rated input current(A) (Note1) | HD | 14 | 18 | 21 | 26 | 35 | 40 | 47 | 63 | 74 | 101 | 114 | 157 | |
| | ND | 18 | 21 | 26 | 35 | 40 | 47 | 63 | 74 | 101 | 114 | 157 | 167 | |
| Cooling method | Forced air cooling | | | | | | | | | | | | | |
| Weight(kg) | 3 | 3 | 6 | 6 | 6 | 10 | 10 | 10 | 11 | 25 | 26 | 30 | | |

| Frame | | E | | F | | G | | H | | | |
|------------------------------------------------|--------------------------------|------------------------------------------------|------------------------------------------------|-----------|-----------|-----------|-----------|-----------|-----------|-----------|-----|
| Model SF3-043- □ K □ KG | | 110 / 90 | 132 / 110 | 160 / 132 | 185 / 160 | 220 / 185 | 250 / 220 | 280 / 250 | 315 / 280 | 355 / 315 | |
| Output | ND | Rated output capacity (kVA) | 168 | 198 | 236 | 295 | 367 | 402 | 438 | 491 | 544 |
| | | Rated output current (A) | 220 | 260 | 310 | 340 | 425 | 480 | 530 | 620 | 683 |
| | | Applicable motor capacity (HP) | 150 | 175 | 215 | 250 | 300 | 355 | 375 | 420 | 475 |
| | | Applicable motor capacity(kW) | 110 | 132 | 160 | 185 | 220 | 250 | 280 | 315 | 355 |
| | | Overload current rating | 120% 60 seconds (inverse time characteristics) | | | | | | | | |
| | Carrier frequency (kHz) | 1~9kHz | | | | | | | | | |
| | HD | Rated output capacity (kVA) | 137 | 168 | 198 | 236 | 295 | 367 | 402 | 438 | 491 |
| | | Rated output current (A) | 180 | 220 | 260 | 310 | 340 | 425 | 480 | 530 | 620 |
| | | Applicable motor capacity (HP) | 120 | 150 | 175 | 215 | 250 | 300 | 335 | 375 | 420 |
| | | Applicable motor capacity (kW) | 90 | 110 | 132 | 160 | 185 | 220 | 250 | 280 | 315 |
| Overload current rating | | 150% 60 seconds (inverse time characteristics) | | | | | | | | | |
| Carrier frequency (kHz) | 1~10kHz | | | | | | | | | | |
| Maximum output voltage | Three-phase 380-480V | | | | | | | | | | |
| Rated power voltage | Three-phase 380-480V 50Hz/60Hz | | | | | | | | | | |
| Allowable fluctuating range of power voltage | Three-phase 323-528V 50Hz/60Hz | | | | | | | | | | |
| Allowable fluctuating range of power frequency | ±5% | | | | | | | | | | |
| Power source capacity (kVA) | 137 | 165 | 198 | 247 | 295 | 367 | 402 | 438 | 491 | | |
| Rated input current(A) (Note1) | HD | 167 | 207 | 240 | 300 | 380 | 400 | 500 | 550 | 650 | |
| | ND | 207 | 240 | 300 | 380 | 400 | 500 | 550 | 650 | 700 | |
| Cooling method | Forced air cooling | | | | | | | | | | |
| Weight(kg) | 38 | 39 | 56 | 56 | 93 | 93 | 93 | 120 | 120 | | |

Note1:

The value of rated input current is not only affected by the power transformer, input reactor and wiring conditions but also fluctuates with the impedance on the power side.

Note:

The test conditions of rated output current, rated output capacity and inverter power consumption are:the carrier frequency (P.72) is at the set value; the inverter output voltage is at 220V; the output frequency is at 60Hz, and the ambient temperature is 40°C.



Common Specifications

| | | |
|---------------------------------------------------|---------------------------------------|----------------------------------------------------------------------------------------------------------------------------------------------------------------------------------------------------------------------------------------------------------------------------------------------------------------------------------------------------------------------------------------|
| Control method | | SVPWM, V/F, general flux vector control, sensorless vector control (SVC). |
| Output frequency range | | 0~599Hz |
| Frequency setting resolution | Digital setting | The resolution is 0.01 Hz when the frequency is set within 100 Hz; The resolution is 0.1 Hz when the frequency is set at above 100 Hz. |
| | Analog setting | 11bit, DC 0~+5V or 4~20mA signal setting; 12bit, DC 0~+10V signal setting |
| Output frequency accuracy | Digital setting | Maximum target frequency $\pm 0.01\%$. |
| | Analog setting | Maximum target frequency $\pm 0.1\%$. |
| Speed control range | | IM: When SVC, 1:200 , PM: When SVC, 1:20. |
| Start torque | | 150% 0.5Hz (SVC). |
| V/F characteristics | | Constant torque curve, variable torque curve, five-point curve, VF separation. |
| Acceleration / deceleration curve characteristics | | Linear acceleration /deceleration curve, S pattern acceleration / deceleration curve1 & 2 & 3. |
| Drive motor | | Induction motor(IM), permanent magnet synchronous motor (SPM, IPM). |
| Current stall protection | | The stall protection level can be set to 0~200%(06-01(P.22)). The default value is 120%(HD) /150%(ND). |
| Target frequency setting | | Keypad setting, DC 0~5V/10V signal, DC -10~+10V signal, DC 4~20 mA signal, multi- speed stage level setting, communication setting, HDI setting. |
| PID control | | Please refer to SF3 user manual. |
| Built-in simple PLC | | Supports 21 basic instructions and 14 application instructions, including PC editing software please refer to manual at build-in PLC chapter. |
| Keypad | Operation monitoring | Output frequency, output current, output voltage, PN voltage, output torque, electronic thermal accumulation rate, temperature rising accumulation rate, output power, analog value input signal, external terminal status... ; at most 12 groups of alarm records, the last group of alarm message is recorded. |
| | LED indicator (8) | Forward rotation indicator, reverse rotation indicator, frequency monitoring indicator, voltage monitoring indicator, current monitoring indicator, mode switch indicator, PU control indicator and external terminal control indicator. |
| Communication | | Built-in Shihlin / Modbus communication protocol, can select MODBUS TCP, CANopen, Profibus, Devicenet, EtherCAT card. |
| Protection mechanism / alarm function | | Output short circuit protection, over-current protection, over-voltage protection, under-voltage protection, motor over-heat protection (06-00(P.9)), IGBT module over-heat protection, communication abnormality protection, PTC temperature protection etc. capacitor overheat, input and output phase loss, to-earth(ground) current leakage protection, circuit error detection... |
| Environment | Ambient temperature | -10 ~ +40°C (non-freezing) |
| | Ambient humidity | Below 90%Rh (non-condensing). |
| | Storage temperature | -20 ~ +65°C. |
| | Surrounding environment | Indoor, no corrosive gas, no flammable gas, no flammable dust. |
| | Altitude | Altitude below 2000. When altitude is above 1000, derate the rated current 2% per 100m. |
| | Vibration | Vibration below 5.9m/s ² (0.6G). |
| | Grade of protection | IP20 for frames A, B and C, IP00 for frame D and above (IP20 accessories is optional) |
| | The degree of environmental pollution | 2 |
| Class of protection | | Class I |
| International certification | | CE |

Wiring Diagram

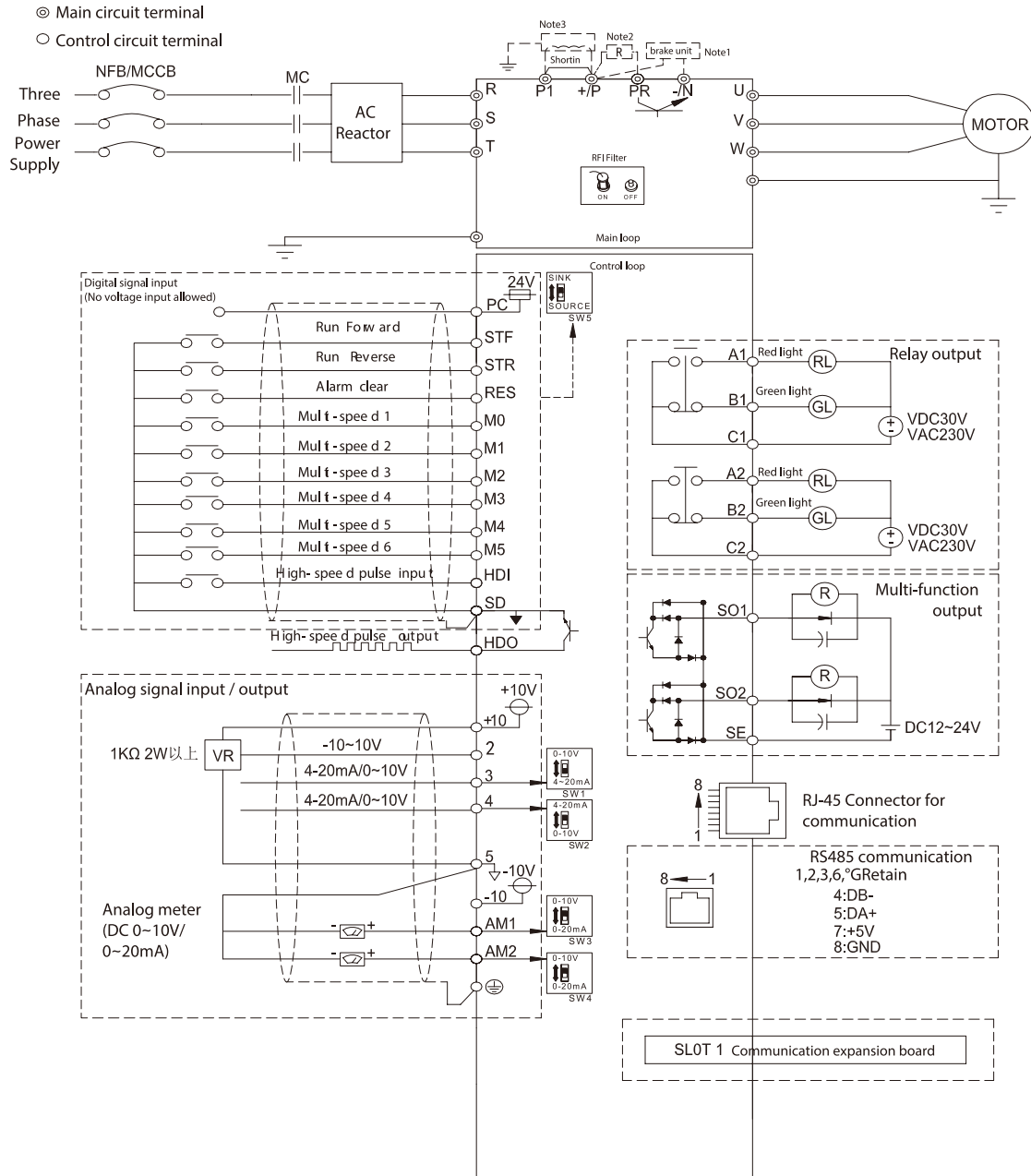

NOTE

1. Braking resistor wiring method between +P and PR is only for frame A, B and C. For frame D, E, G and H, the braking resistor is connect between (+)P(-)N).
2. DC reactor can be added between +P and P1. When DC reactor is not in used, short those terminals.
3. When adding DC reactor, the jumper between +P and P1 must be removed.



SF3

Dimensions

Unit: mm

Frame A

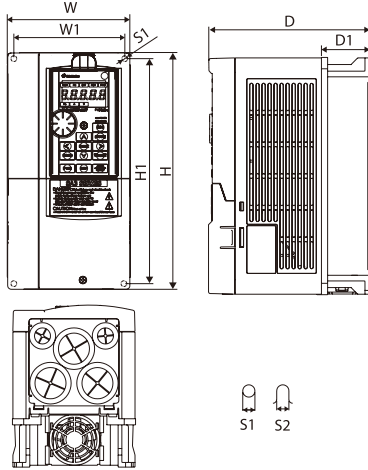

Frame A

| Model type | W (mm) | W1 (mm) | H (mm) | H1 (mm) | D (mm) | D1 (mm) | S1 (mm) | S2 (mm) |
|--------------------|--------|---------|--------|---------|--------|---------|---------|---------|
| SF3-043-5.5K/3.7KG | 130.0 | 116.0 | 250.0 | 236.0 | 170.0 | 51.3 | 6.2 | 6.2 |
| SF3-043-7.5K/5.5KG | | | | | | | | |

Frame B

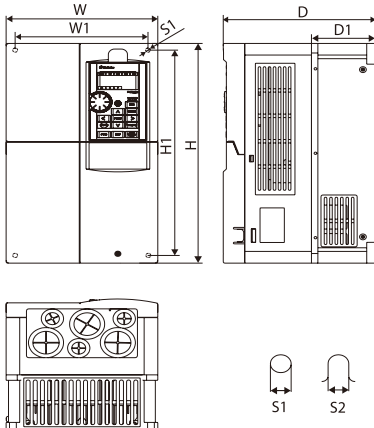

Frame B

| Model type | W (mm) | W1 (mm) | H (mm) | H1 (mm) | D (mm) | D1 (mm) | S1 (mm) | S2 (mm) |
|--------------------|--------|---------|--------|---------|--------|---------|---------|---------|
| SF3-043-11K/7.5KG | 190.0 | 173.0 | 320.0 | 303.0 | 190.0 | 80.5 | 8.5 | 8.5 |
| SF3-043-15K/11KG | | | | | | | | |
| SF3-043-18.5K/15KG | | | | | | | | |

Frame C

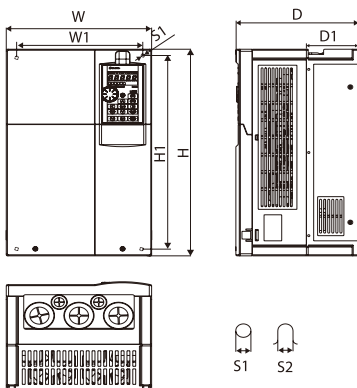

Frame C

| Model type | W (mm) | W1 (mm) | H (mm) | H1 (mm) | D (mm) | D1 (mm) | S1 (mm) | S2 (mm) |
|--------------------|--------|---------|--------|---------|--------|---------|---------|---------|
| SF3-043-22K/18.5KG | 250.0 | 231.0 | 400.0 | 381.0 | 210.0 | 89.5 | 8.5 | 8.5 |
| SF3-043-30K/22KG | | | | | | | | |
| SF3-043-37K/30KG | | | | | | | | |
| SF3-043-45K/37KG | | | | | | | | |

SF3 series

Communication
Vector Control Inverter

Dimensions

Unit: mm

Frame D

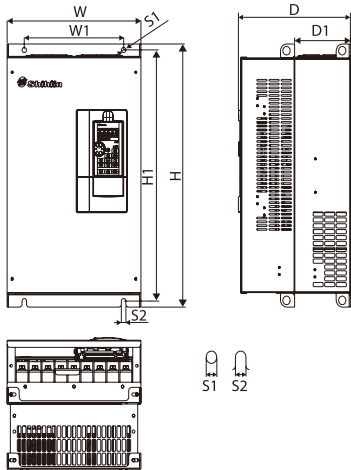

Frame D

| Model type | W (mm) | W1 (mm) | H (mm) | H1 (mm) | D (mm) | D1 (mm) | S1 (mm) | S2 (mm) |
|------------------|--------|---------|--------|---------|--------|---------|---------|---------|
| SF3-043-55K/45KG | 330.0 | 245.0 | 550.0 | 525.0 | 275.0 | 137.5 | 11.0 | 11.0 |
| SF3-043-75K/55KG | | | | | | | | |
| SF3-043-90K/75KG | | | | | | | | |

Frame E

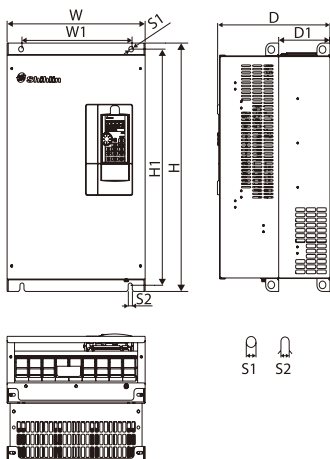

Frame E

| Model type | W (mm) | W1 (mm) | H (mm) | H1 (mm) | D (mm) | D1 (mm) | S1 (mm) | S2 (mm) |
|--------------------|--------|---------|--------|---------|--------|---------|---------|---------|
| SF3-043-110K/90KG | 370.0 | 295.0 | 589.0 | 560.0 | 300.0 | 137.5 | 11.0 | 11.0 |
| SF3-043-132K/110KG | | | | | | | | |

Frame F

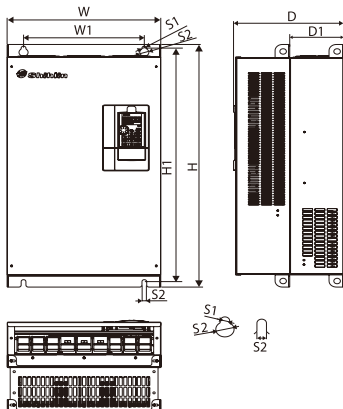

Frame F

| Model type | W (mm) | W1 (mm) | H (mm) | H1 (mm) | D (mm) | D1 (mm) | S1 (mm) | S2 (mm) | S3 (mm) |
|--------------------|--------|---------|--------|---------|--------|---------|---------|---------|---------|
| SF3-043-160K/132KG | 420.0 | 330.0 | 800.0 | 770.0 | 300.0 | 145.5 | 13.0 | 25.0 | 13.0 |
| SF3-043-185K/160KG | | | | | | | | | |



SF3

Dimensions

Unit : mm

Frame G

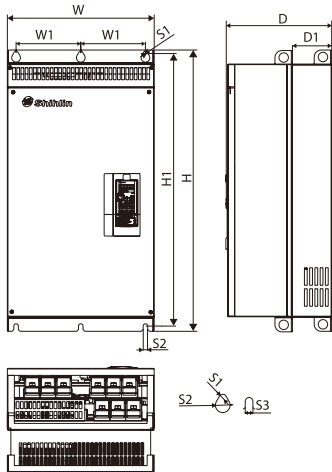

Frame G

| Model type | W (mm) | W1 (mm) | H (mm) | H1 (mm) | D (mm) | D1 (mm) | S1 (mm) | S2 (mm) | S3 (mm) |
|--------------------|--------|---------|--------|---------|--------|---------|---------|---------|---------|
| SF3-043-220K/185KG | 500.0 | 180.0 | 870.0 | 850.0 | 360.0 | 150.0 | 13.0 | 25.0 | 13.0 |
| SF3-043-250K/220KG | | | | | | | | | |
| SF3-043-280K/250KG | | | | | | | | | |

Frame H

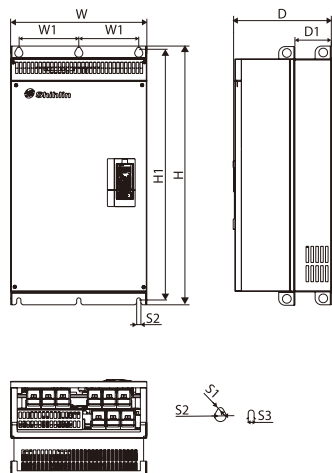

Frame H

| Model type | W (mm) | W1 (mm) | H (mm) | H1 (mm) | D (mm) | D1 (mm) | S1 (mm) | S2 (mm) | S3 (mm) |
|--------------------|--------|---------|--------|---------|--------|---------|---------|---------|---------|
| SF3-043-315K/280KG | 600.0 | 230.0 | 1000.0 | 980.0 | 400.0 | 181.5 | 13.0 | 25.0 | 13.0 |
| SF3-043-355K/315KG | | | | | | | | | |

Keypad Dimensions

PU301、PU301C

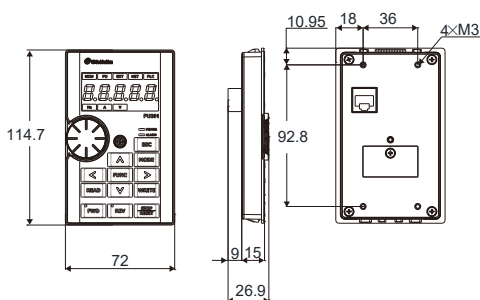

Flat Spring Installation

SMK301 (PU301, PU301C Mounting kit)

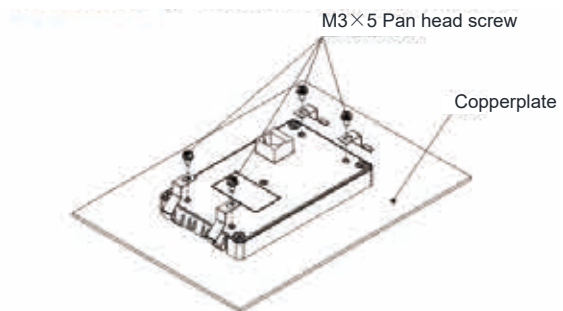

SA3 series

Advanced Closed Loop
Communication Inverter

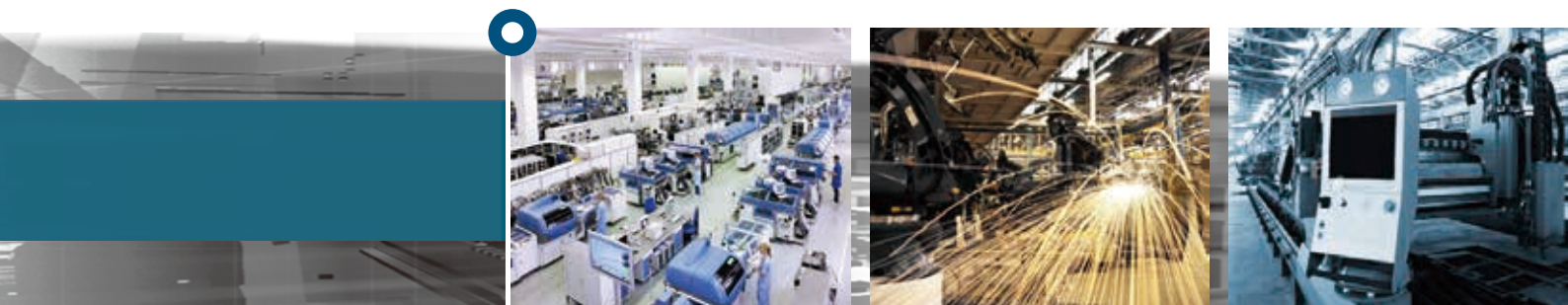

Product Range

| Model | | kW (HP) | 0.75 (1) | 1.5 (2) | 2.2 (3) | 3.7 (5) | 5.5 (7.5) | 7.5 (10) | 11 (15) | 15 (20) | 18.5 (25) | 22 (30) | 30 (40) | 37 (50) | 45 (60) | 55 (75) | 75 (100) | 90 (120) | 110 (150) | 132 (175) | 160 (215) | 185 (250) | 220 (300) | 250 (335) | 280 (375) | 315 (420) | 355 (475) | | |
|-------|-----------------------------|---------|--------------------------------|---------|---------|---------|-----------|----------|---------|---------|-----------|---------|---------|---------|---------|---------|----------|----------|-----------|-----------|-----------|-----------|-----------|-----------|-----------|-----------|-----------|--|--|
| SA3 | S A 3 - 3 phase 023 220V | 150%60s | [Blue bar with diagonal lines] | | | | | | | | | | | | | | | | | | | | | | | | | | |
| | | 200%3s | [Blue bar with diagonal lines] | | | | | | | | | | | | | | | | | | | | | | | | | | |
| | S A 3 - 3 phase 043 440V | 150%60s | [Blue bar with diagonal lines] | | | | | | | | | | | | | | | | | | | | | | | | | | |
| | | 200%3s | [Blue bar with diagonal lines] | | | | | | | | | | | | | | | | | | | | | | | | | | |
| | | 120%60s | [Blue bar with diagonal lines] | | | | | | | | | | | | | | | | | | | | | | | | | | |

Product Features

High Performance Vector Control Technology

- Vector control and Sensorless vector control.
- High starting torque: Sensorless vector control (SVC) 150% 0.3Hz, and closed-loop vector control(FOC + PG) 180% 0Hz.

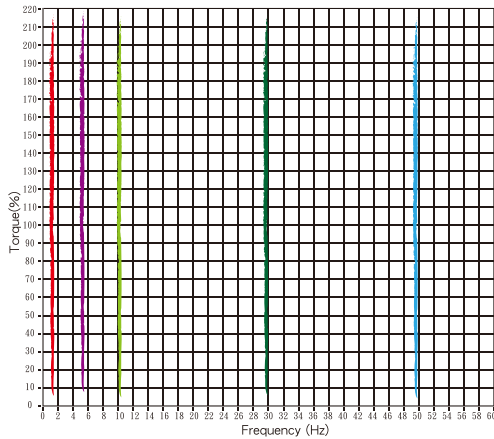

High Response Performance

- Speed accuracy: less than 1% with 0 to 100% load variation.
- For applications with sudden load changes such as cranes and metal processing machinery.

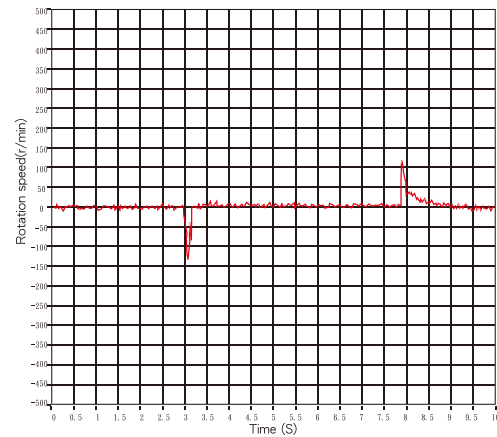

Excellent Overload Endurance

- With a current overload capability of 150% for 60 seconds and 200% for 3 seconds, the setting is suitable for handling large sudden load changes applications such as tooling machinery.

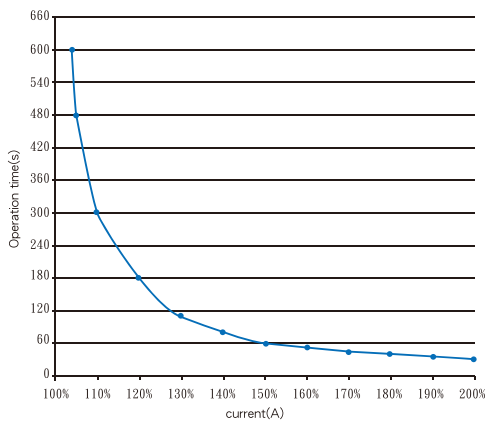

4-Quadrant Torque Control and Limits

- Parameters or analog signals can be used to simply establish limits for 4 torque items.

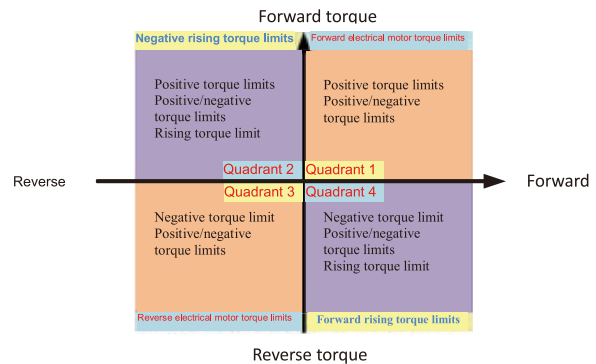

Product Features

Temporary Compensation at Low Voltage

- When temporary shut-down occurs, output frequency will be controlled to maintain DC bus voltage of the inverter to decelerate the motor.
- When power resumes, inverter will control the motor to accelerate to its previous speed.
- Applicable for machines that are not able to commence free-run while decelerating.

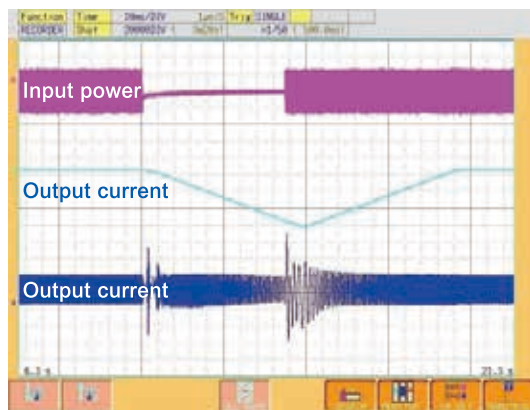

Magnetic Flux Brake

- When the motor is stopping, the magnetic flux will be transmitted to the motor coil to shorten deceleration time without relying on regenerative resistance.

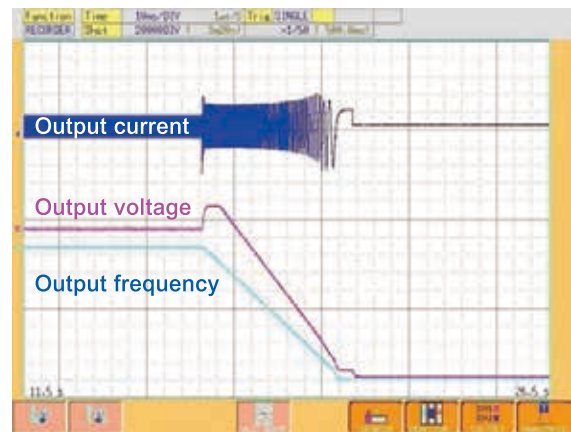

Regeneration Avoidance Functions

- By adjusting output frequency and voltage, DC bus voltage can be kept at a specified value and prevent overvoltage.

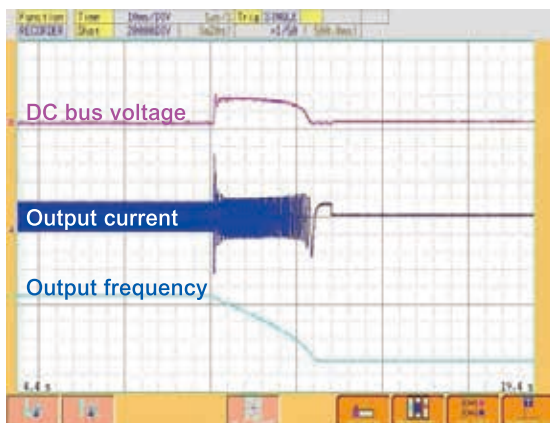

Low-noise Carrier Wave Control (Soft-PWM)

- Motor noise is controlled so that the metallic sound is transformed into a more pleasing buzz.
- Low noise operations to reduce the interference exerted upon external radio frequencies.

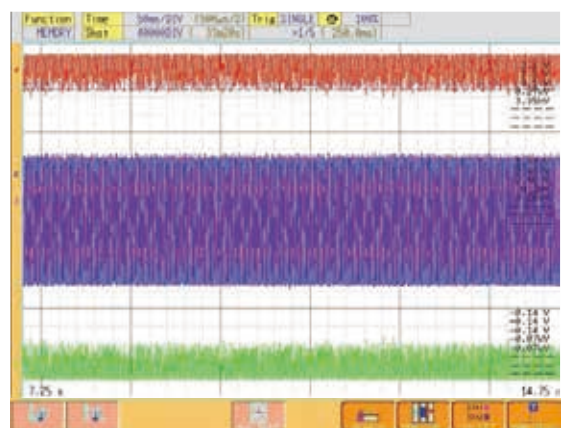



SA3

Product Features

Advanced Synchronous Motors Control Technology

- Support both induction and permanent magnet motors with open-loop control.



LCD Operation Interface

- Support 2 display styles.
- Able to simultaneously display 6 sets of operational data.
- Calendar support.
- Offer both English and Chinese language interfaces.
- Capable of storing 3 sets of parameters.
- Support shuttle settings.



Isolated Air Channel

- Fan wind channels are sealed and isolated from the heat dissipation system and electrical parts. Dust will not be able to infiltrate the interior of the machine through the fans.

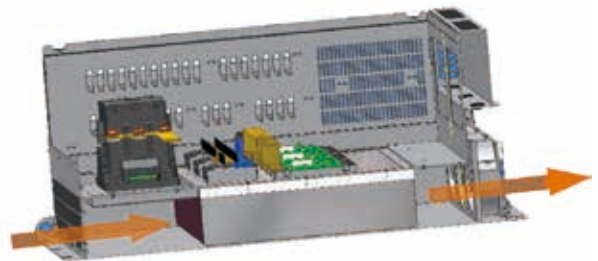

Multiple Control Modes for Various Applications

- Position / Speed / Torque / Tension control mode
- Combination mode (e.g. speed+torque) can be achieved via I/O switch.
- Advanced position control functions: Homing commands, zero speed, Pr/Pt mode(with optional PG cards).
- Support open-loop tension control, feeding disruption inspection and automatic spool replacement functions.

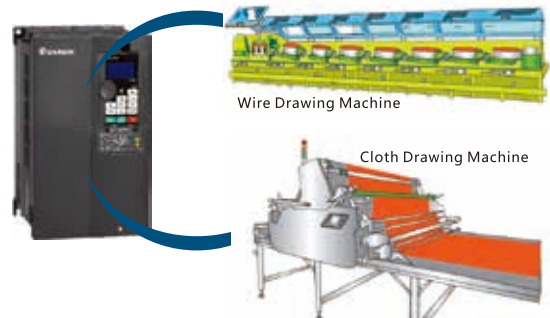

Product Features

Multiple I/O Terminals

- Include 10 sets of multi-functional combinational logic input terminals (with high-speed pulse inputs *1)
- Include 5 sets of multi-functional combinational output terminals (including electric relay output *2, transistor output *2, and high-speed pulse output *1).
- Include 3 sets of analog input signals (with -10~+10V*1 and 4~20mA/0~10V*2).
- Include 2 sets of analog output signals (0~20mA/0~10V*2).
- 1 set of safety switch (S1~SC).

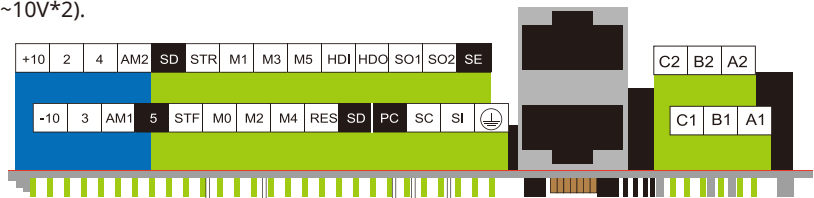

Built-in PLC Functions

- Provide PLC programming software, easy for editing.
- Applicable for programming small number of points, and support multiple functions.

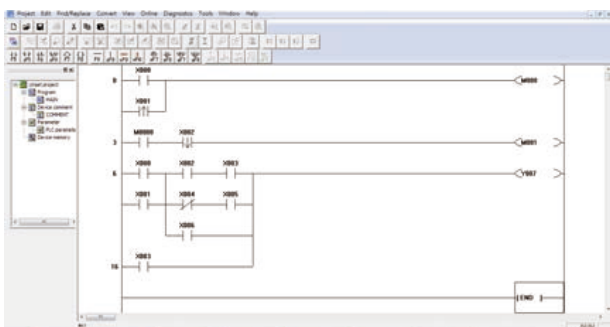

| Item | SA3 PLC functions | |
|-------------------------------|--------------------------|------------------------------------------------|
| Programming Language | Ladder diagram + Command | |
| Basic commands | 21 | |
| Applicable commands | 14 | |
| Processing speed | Basic commands | 1 μs |
| | Applicable commands | 10 μs |
| Hidden program capacity | 400 steps(0-399 steps) | |
| I/O configuration | Input(X) | 22 points(X0-X25, octal) |
| | Output(Y) | 20 points(Y0-Y23, octal) |
| Supporting electric relay (M) | General | 160 points, M0-M159 |
| | Battery backed | 80 points, M160-M239 |
| | Special | 64 points, M8000-M8063 |
| Timer(T) | 100ms | 8 points, T0-T7, timer range: 0~6553.5 seconds |
| Counter(C) | | 8 points, C0-C7, counting range: 0~65535 |
| Data register | General | 32 points, D0-D31 |
| | Battery backed | 16 points, D32-D47 |
| | Special | 64 points, D8000-D8063 |

Through-the-wall Installation Support Provided for the Entire Series

- Improve heat dissipation, reduce heat generation within the cabinet, and improve protection for the cabinet contents.

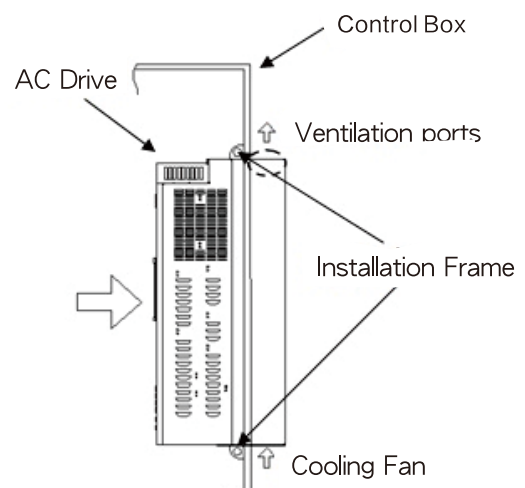

12 Sets of Alarm Records

- Complete alarm system for recording the output frequency, output current, output voltage, accumulated count of temperature increase, PN voltage, total operation time, operational status, alarm output time(only when used with PU301C).

Improved Protection

- Output phase failure protection, output short circuit protection, ground leakage protection, low voltage protection, motor overheating signal (PTC), and electrolytic capacitor life inspection.

Built-in RFI filter

- Reduce electromagnetic interference.

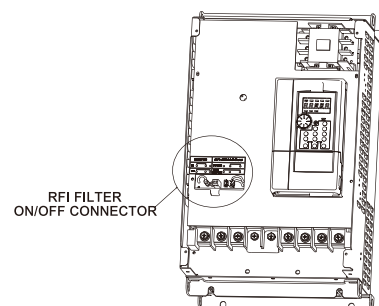



SA3

Model Identification

SA3 **043 0.75K/1.5KF** **XY**

| Series | Voltage level | Capacity | Version |
|------------|--------------------------------------------------|---------------------------|------------------------------------------------------------------------------|
| SA3 series | 043 : three phase 440V 023 : three phase 220V | HD : 0.75kW ND : 1.5kW | None : General model -xy : Customized or specialized or region difference |

Electrical Specifications

220V Three-phase Series

| Frame | | A | | | | B | | | C | | D | | | E | | F | G | | | | | |
|------------------------|-----------------------------------------|--------------------------------|----------------------------------|---------------------------------------------------------------|---------------|---------------|--------------|-------------|---------------|---------------|-------------|-------------|-------------|-------------|-------------|-------------|--------------|---------------|------|-----|--|--|
| Model SA3-023- □ -xy | | 075K 1.5KF | 1.5K 2.2KF | 2.2K 3.7KF | 3.7K 5.5KF | 5.5K 7.5KF | 7.5K 11KF | 11K 15KF | 15K 18.5KF | 18.5K 22KF | 22K 30KF | 30K 37KF | 37K 45KF | 45K 55KF | 55K 75KF | 75K 90KF | 90K 110KF | 110K 132KF | | | | |
| Output | HD | Rated output capacity (kVA) | | 2 | 3.2 | 4.2 | 6.7 | 9.5 | 12.5 | 18.3 | 24.7 | 28.6 | 34.3 | 45.7 | 55 | 65 | 82 | 110 | 132 | 165 | | |
| | | Rated output current (A) | | 5 | 8 | 11 | 17.5 | 25 | 33 | 49 | 65 | 75 | 90 | 120 | 145 | 170 | 215 | 288 | 346 | 432 | | |
| | | Applicable motor capacity (HP) | | 1 | 2 | 3 | 5 | 7.5 | 10 | 15 | 20 | 25 | 30 | 40 | 50 | 60 | 75 | 100 | 120 | 145 | | |
| | | Applicable motor capacity(kW) | | 0.75 | 1.5 | 2.2 | 3.7 | 5.5 | 7.5 | 11 | 15 | 18.5 | 22 | 30 | 37 | 45 | 55 | 75 | 90 | 110 | | |
| | | Overload current rating | | 150% 60 seconds 200% 3 seconds (inverse time characteristics) | | | | | | | | | | | | | | | | | | |
| | | Carrier frequency (kHz) | | 1~15kHz | | | | | | | | | | 1~9kHz | | | | | | | | |
| | ND | Rated output capacity (kVA) | | 3.2 | 4.2 | 6.7 | 9.5 | 12.5 | 18.3 | 24.7 | 28.6 | 34.3 | 45.7 | 55 | 65 | 82 | 110 | 132 | 165 | 193 | | |
| | | Rated output current (A) | | 8 | 11 | 17.5 | 25 | 33 | 49 | 65 | 75 | 90 | 120 | 145 | 170 | 215 | 288 | 346 | 432 | 506 | | |
| | | Applicable motor capacity (HP) | | 2 | 3 | 5 | 7.5 | 10 | 15 | 20 | 25 | 30 | 40 | 50 | 60 | 75 | 100 | 120 | 145 | 175 | | |
| | | Applicable motor capacity (kW) | | 1.5 | 2.2 | 3.7 | 5.5 | 7.5 | 11 | 15 | 18.5 | 22 | 30 | 37 | 45 | 55 | 75 | 90 | 110 | 132 | | |
| | | Overload current rating | | 120% 60 seconds (inverse time characteristics) | | | | | | | | | | | | | | | | | | |
| | | Carrier frequency (kHz) | | 1~15kHz | | | | | | | | | | 1~9kHz | | | | | | | | |
| Maximum output voltage | | Three-phase 200-240V | | | | | | | | | | | | | | | | | | | | |
| Power supply | Rated power voltage | | Three-phase 200-240V 50Hz / 60Hz | | | | | | | | | | | | | | | | | | | |
| | Power voltage permissible fluctuation | | Three-phase 170-264V 50Hz / 60Hz | | | | | | | | | | | | | | | | | | | |
| | Power frequency permissible fluctuation | | ±5% | | | | | | | | | | | | | | | | | | | |
| | Power source capacity (kVA) | | 2.5 | 4.5 | 6.4 | 10 | 12 | 17 | 20 | 28 | 34 | 41 | 52 | 65 | 79 | 100 | 110 | 132 | 165 | | | |
| | Rated input current(A) (Note1) | HD | 6 | 12 | 16 | 20 | 28 | 35 | 52 | 72 | 83 | 93 | 124 | 143 | 180 | 250 | 300 | 380 | 450 | | | |
| | | ND | 12 | 16 | 20 | 28 | 35 | 52 | 72 | 83 | 93 | 124 | 142 | 180 | 250 | 300 | 380 | 450 | 520 | | | |
| Cooling method | | Self cooling | | Forced air cooling | | | | | | | | | | | | | | | | | | |
| Weight(kg) | | 3.15 | 3.15 | 3.15 | 3.15 | 6 | 6 | 6 | 6 | 10.6 | 10.6 | 33 | 33 | 33 | 42.7 | 42.7 | 56.5 | 89.2 | 90.2 | | | |

Note1:

The value of rated input current is not only affected by the power transformer, input reactor and wiring conditions but also fluctuates with the impedance on the power side.

Note:

The test conditions of rated output current, rated output capacity and inverter power consumption are:the carrier frequency (P.72) is at the set value; the inverter output voltage is at 220V; the output frequency is at 60Hz, and the ambient temperature is 40°C.

Electrical Specifications

440 V Three-phase Series

| Frame | | A | | | | | B | | | C | | | D | |
|-----------------------------------------|----------------------------------|------------------------------------------------|---------------------------------------------------------------|---------------|---------------|---------------|--------------|-------------|---------------|---------------|-------------|-------------|-------------|----|
| Model SA3-043-□-xy | | 0.75K 1.5KF | 1.5K 2.2KF | 2.2K 3.7KF | 3.7K 5.5KF | 5.5K 7.5KF | 7.5K 11KF | 11K 15KF | 15K 18.5KF | 18.5K 22KF | 22K 30KF | 30K 37KF | 37K 45KF | |
| Output | HD | Rated output capacity (kVA) | 2 | 3 | 4.6 | 6.9 | 10 | 14 | 18 | 25 | 29 | 34 | 46 | 56 |
| | | Rated output current (A) | 3.0 | 4.2 | 6 | 9 | 12 | 17 | 24 | 32 | 38 | 45 | 60 | 73 |
| | | Applicable motor capacity (HP) | 1 | 2 | 3 | 5 | 7.5 | 10 | 15 | 20 | 25 | 30 | 40 | 50 |
| | | Applicable motor capacity(kW) | 0.75 | 1.5 | 2.2 | 3.7 | 5.5 | 7.5 | 11 | 15 | 18.5 | 22 | 30 | 37 |
| | | Overload current rating | 150% 60 seconds 200% 3 seconds (inverse time characteristics) | | | | | | | | | | | |
| | Carrier frequency (kHz) | 1~15kHz | | | | | | | | | | | | |
| | ND | Rated output capacity (kVA) | 3 | 4.6 | 6.9 | 10 | 14 | 18 | 25 | 29 | 34 | 46 | 56 | 69 |
| | | Rated output current (A) | 4.2 | 6 | 9 | 12 | 17 | 24 | 32 | 38 | 45 | 60 | 73 | 91 |
| | | Applicable motor capacity (HP) | 2 | 3 | 5 | 7.5 | 10 | 15 | 20 | 25 | 30 | 40 | 50 | 60 |
| | | Applicable motor capacity (kW) | 1.5 | 2.2 | 3.7 | 5.5 | 7.5 | 11 | 15 | 18.5 | 22 | 30 | 37 | 45 |
| Overload current rating | | 120% 60 seconds (inverse time characteristics) | | | | | | | | | | | | |
| Carrier frequency (kHz) | 1~15kHz | | | | | | | | | | | | | |
| Maximum output voltage | Three-phase 380-480V | | | | | | | | | | | | | |
| Rated power voltage | Three-phase 380-480V 50Hz / 60Hz | | | | | | | | | | | | | |
| Power voltage permissible fluctuation | Three-phase 323-528V 50Hz / 60Hz | | | | | | | | | | | | | |
| Power frequency permissible fluctuation | ±5% | | | | | | | | | | | | | |
| Power source capacity (kVA) | 2.5 | 4.5 | 6.9 | 10.4 | 11.5 | 16 | 20 | 27 | 32 | 41 | 52 | 65 | 65 | |
| Rated input current(A) (Note1) | HD | 4.0 | 5.9 | 8.7 | 14 | 17 | 20 | 26 | 35 | 40 | 47 | 63 | 74 | |
| | ND | 5.9 | 8.7 | 14 | 17 | 20 | 26 | 35 | 40 | 47 | 63 | 74 | 101 | |
| Cooling method | Self cooling | | Forced air cooling | | | | | | | | | | | |
| Weight(kg) | 3.15 | 3.15 | 3.15 | 3.15 | 3.15 | 6 | 6 | 6 | 9.8 | 9.8 | 9.8 | 33 | 33 | |

| Frame | | D | | | E | | F | | G | | | H | | |
|-----------------------------------------|----------------------------------|------------------------------------------------|--------------------------------------------------------------|-------------|--------------|---------------|---------------|---------------|---------------|---------------|---------------|---------------|---------------|-----|
| Model SA3-043-□-xy | | 45K 55KF | 55K 75KF | 75K 90KF | 90K 110KF | 110K 132KF | 132K 160KF | 160K 185KF | 185K 220KF | 220K 250KF | 250K 280KF | 280K 315KF | 315K 355KF | |
| Output | HD | Rated output capacity (kVA) | 69 | 84 | 114 | 137 | 168 | 198 | 236 | 295 | 367 | 402 | 438 | 491 |
| | | Rated output current (A) | 91 | 110 | 150 | 180 | 220 | 260 | 310 | 340 | 425 | 480 | 530 | 620 |
| | | Applicable motor capacity (HP) | 60 | 75 | 100 | 120 | 150 | 175 | 215 | 250 | 300 | 335 | 375 | 420 |
| | | Applicable motor capacity(kW) | 45 | 55 | 75 | 90 | 110 | 132 | 160 | 185 | 220 | 250 | 280 | 315 |
| | | Overload current rating | 150% 60 seconds 200% 3seconds (inverse time characteristics) | | | | | | | | | | | |
| | Carrier frequency (kHz) | 1~9kHz | | | | | | | | | | | | |
| | ND | Rated output capacity (kVA) | 84 | 114 | 137 | 168 | 198 | 236 | 295 | 367 | 402 | 438 | 491 | 544 |
| | | Rated output current (A) | 110 | 150 | 180 | 220 | 260 | 310 | 340 | 425 | 480 | 530 | 620 | 683 |
| | | Applicable motor capacity (HP) | 75 | 100 | 120 | 150 | 175 | 215 | 250 | 300 | 335 | 375 | 420 | 475 |
| | | Applicable motor capacity (kW) | 55 | 75 | 90 | 110 | 132 | 160 | 185 | 220 | 250 | 280 | 315 | 355 |
| Overload current rating | | 120% 60 seconds (inverse time characteristics) | | | | | | | | | | | | |
| Carrier frequency (kHz) | 1~9kHz | | | | | | | | | | | | | |
| Maximum output voltage | Three-phase 380-480V | | | | | | | | | | | | | |
| Rated power voltage | Three-phase 380-480V 50Hz / 60Hz | | | | | | | | | | | | | |
| Power voltage permissible fluctuation | Three-phase 323-528V 50Hz / 60Hz | | | | | | | | | | | | | |
| Power frequency permissible fluctuation | ±5% | | | | | | | | | | | | | |
| Power source capacity (kVA) | 79 | 100 | 110 | 137 | 165 | 198 | 247 | 295 | 367 | 402 | 438 | 491 | 491 | |
| Rated input current(A) (Note1) | HD | 101 | 114 | 157 | 167 | 207 | 240 | 300 | 380 | 400 | 500 | 550 | 650 | |
| | ND | 114 | 157 | 167 | 207 | 240 | 300 | 380 | 400 | 500 | 550 | 650 | 700 | |
| Cooling method | Self cooling | | Forced air cooling | | | | | | | | | | | |
| Weight(kg) | 33 | 33 | 33 | 42.7 | 42.7 | 56.5 | 84 | 84 | 84 | 84 | 123 | 123 | 123 | |

Note1:

The value of rated input current is not only affected by the power transformer, input reactor and wiring conditions but also fluctuates with the impedance on the power side.

Note:

The test conditions of rated output current, rated output capacity and inverter power consumption are:the carrier frequency (P.72) is at the set value; the inverter output voltage is at 220V; the output frequency is at 60Hz, and the ambient temperature is 40°C.



SA3

Common Specifications

| | | |
|---------------------------------------------------|---------------------------------------|------------------------------------------------------------------------------------------------------------------------------------------------------------------------------------------------------------------------------------------------------------------------------------------------------------------------------------------------------------------------------------------------------------------------------------------------------------------------------|
| Control method | | SVPWM control, V/F control, close-loop V/F control (VF+PG), general flux vector control, sensorless vector control (SVC), close-loop vector control (FOC+PG), torque control (TQC+PG). |
| Output frequency range | | 0~599.00Hz |
| Frequency setting resolution | Digital setting | The resolution is 0.01Hz. |
| | Analog setting | 0.01Hz/60Hz (terminal 2: -10 ~ +10V / 13bit) 0.015Hz/60Hz (terminal 2: 0 ~ ±10V / 12bit; terminal 3: 0~10V, 4-20mA / 12bit) 0.03Hz/60Hz (terminal 2, 3; 0 ~ 5V / 11bit) 0.06Hz/60Hz (terminal 4: 0~10V, 4-20mA /10bit) 0.12Hz/60Hz (terminal 4: 0 ~ 5V /9bit) |
| Output frequency accuracy | Digital setting | Maximum target frequency ± 0.01%. |
| | Analog setting | Maximum target frequency ± 0.1%. |
| Speed control range | | IM: When SVC, 1:200; when FOC+PG, 1:1000. PM: When SVC, 1:20; when FOC+PG, 1:1000. |
| Start torque | | 150% 0.3Hz (SVC), 180% 0Hz (FOC+PG). |
| V/F characteristics | | Constant torque curve, variable torque curve, five-point curve, VF separation |
| Acceleration / deceleration curve characteristics | | Linear acceleration / deceleration curve, S shape acceleration / deceleration curve 1 & 2 & 3 |
| Drive motor | | Induction motor (IM), permanent magnet motor (SPM, IPM) |
| Stalling protection | | The stalling protection level can be set to 0~400% (06-01(P.22)). The default value is 150%. |
| Target frequency setting | | Keypad setting, DC 0~5V/10V signal, DC -10~+10V signal, DC 4~20 mA signal, multi-speed stage level setting, communication setting, HDI setting. |
| PID control | | Please refer to 08-00~08-01、08-04~08-14 / P.170~P.182 in chapter 4. |
| Built-in simple PLC | | Supports 21 basic instructions and 14 application instructions, including PC editing software; |
| Keypad | Operation monitoring | Output frequency, output current, output voltage, PN voltage, output torque, electronic thermal accumulation rate, temperature rising accumulation rate, output power, analog value input signal, digital input and output terminal status...; alarm history 12 groups at most, the last group of alarm message is recorded. |
| | LED indicator (10) | Forward rotation indicator, reverse rotation indicator, frequency monitoring indicator, voltage monitoring indicator, current monitoring indicator, NET indicator, PU control indicator, EXT indicator, PLC indicator and MON monitoring indicator. |
| Communication function | | Built-in Shihlin/Modbus communication protocol, can select MODBUS TCP, CANopen, Profibus, Devicenet, EtherCAT card. |
| Protection mechanism / alarm function | | Output short circuit protection, Over-current protection, over-voltage protection, under-voltage protection, motor over-heat protection (06-00(P.9)), IGBT module over-heat protection, communication abnormality protection, PTC temperature protection etc, electrolytic capacitor overheat, input and output phase failure, to-earth (ground) leakage currents protection, circuit error detection... |
| Environment | Ambient temperature | Heavy duty : -10 ~ +50°C (non-freezing), Light duty : -10 ~ +40°C (non-freezing), please refer to 3.4.5 Class of protection and operation temperature for details. |
| | Ambient humidity | Below 90%Rh (non-condensing). |
| | Storage temperature | -20 ~ +65°C |
| | Surrounding environment | Indoor, no corrosive gas, no flammable gas, no flammable dust. |
| | Altitude | Altitude below 3000 meters, when altitude is above 1,000 m, derate the rated current 2% per 100 m Note 1: According to the safety regulation EN61800-5-1, which is required to declare in CE certification, this series of inverters can be installed in an environment of over-voltage class II when the altitude is less than 3000m. When the altitude is less than 2000m, can be installed in harsher conditions that meet the requirements of over-voltage class III. |
| | Vibration | Vibration below 5.9m/s ² (0.6G) |
| | Grade of protection | Frame A, B, C, IP20 / NEMA TYPE 1, Frame D and above IP00 / UL OPEN TYPE (optional IP20 accessories can be added). |
| | The degree of environmental pollution | 2 |
| Class of protection | | Class I |
| International certification | | CE |

Wiring Diagram

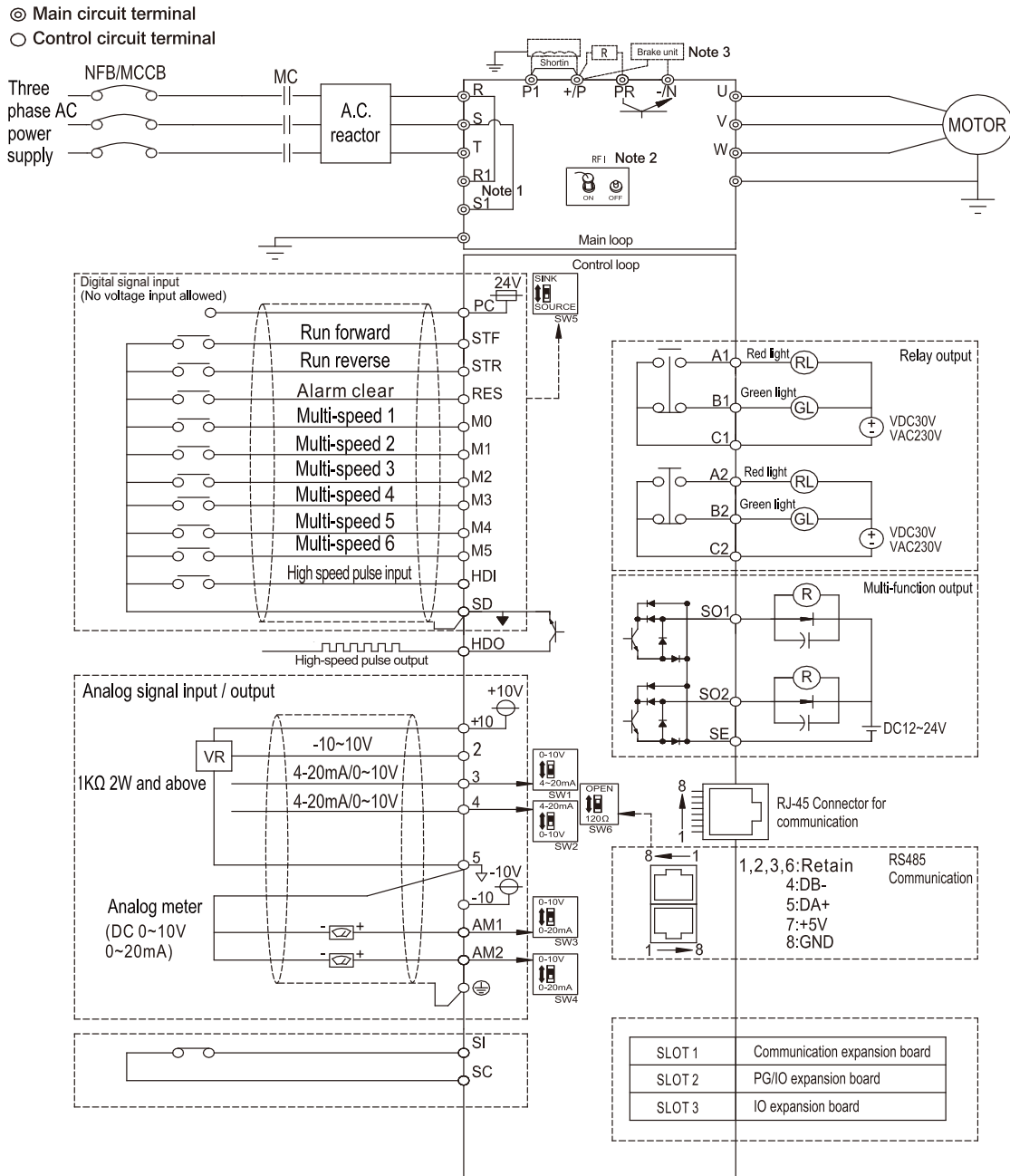

NOTE

- 1.R1 S1 terminal is only for frame D~H.
- 2.The connection of braking resistor between +/P and PR is only for frame A, B and C. For frame D and above, please connect a braking unit between +/P and -/N.
- 3.The DC reactor between + / P and P1 is optional, please short + / P and P1 when DC reactor is not used.



SA3

Dimensions

Unit : mm

Frame A

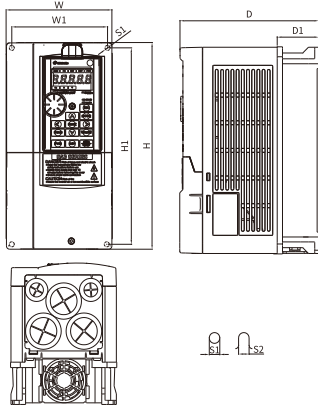

Frame A

| Model type | W (mm) | W1 (mm) | H (mm) | H1 (mm) | D (mm) | D1 (mm) | S1 (mm) | S2 (mm) |
|---------------------|--------|---------|--------|---------|--------|---------|---------|---------|
| SA3-043-0.75K/1.5KF | 130.0 | 116.0 | 250.0 | 236.0 | 170.0 | 51.3 | 6.2 | 6.2 |
| SA3-043-1.5K/2.2KF | | | | | | | | |
| SA3-043-2.2K/3.7KF | | | | | | | | |
| SA3-043-3.7K/5.5KF | | | | | | | | |
| SA3-043-5.5K/7.5KF | | | | | | | | |
| SA3-023-0.75K/1.5KF | | | | | | | | |
| SA3-023-1.5K/2.2KF | | | | | | | | |
| SA3-023-2.2K/3.7KF | | | | | | | | |
| SA3-023-3.7K/5.5KF | | | | | | | | |

Frame B

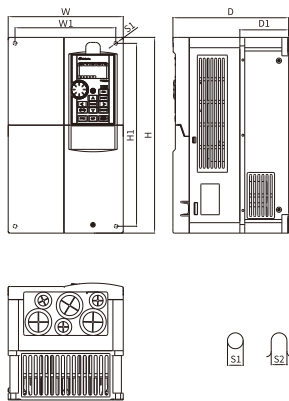

Frame B

| Model type | W (mm) | W1 (mm) | H (mm) | H1 (mm) | D (mm) | D1 (mm) | S1 (mm) | S2 (mm) |
|--------------------|--------|---------|--------|---------|--------|---------|---------|---------|
| SA3-043-7.5K/11KF | 190.0 | 173.0 | 320.0 | 303.0 | 190.0 | 80.5 | 8.5 | 8.5 |
| SA3-043-11K/15KF | | | | | | | | |
| SA3-043-15K/18.5KF | | | | | | | | |
| SA3-023-5.5K/7.5KF | | | | | | | | |
| SA3-023-7.5K/11KF | | | | | | | | |
| SA3-023-11K/15KF | | | | | | | | |

Frame C

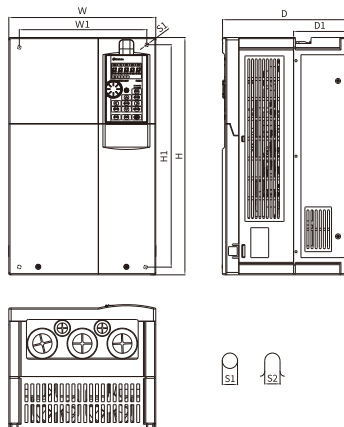

Frame C

| Model type | W (mm) | W1 (mm) | H (mm) | H1 (mm) | D (mm) | D1 (mm) | S1 (mm) | S2 (mm) |
|--------------------|--------|---------|--------|---------|--------|---------|---------|---------|
| SA3-043-18.5K/22KF | 250.0 | 231.0 | 400.0 | 381.0 | 210.0 | 89.5 | 8.5 | 8.5 |
| SA3-043-22K/30KF | | | | | | | | |
| SA3-043-30K/37KF | | | | | | | | |
| SA3-023-15K/18.5KF | | | | | | | | |
| SA3-023-18.5K/22KF | | | | | | | | |

Dimensions

Unit : mm

Frame D

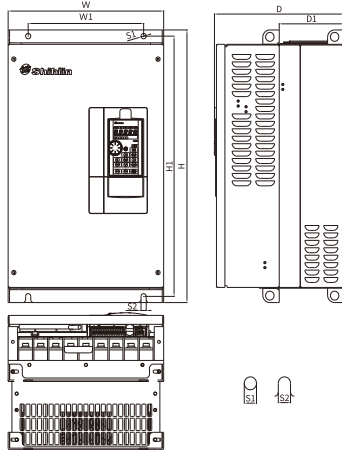

Frame D

| Model type | W (mm) | W1 (mm) | H (mm) | H1 (mm) | D (mm) | D1 (mm) | S1 (mm) | S2 (mm) |
|------------------|--------|---------|--------|---------|--------|---------|---------|---------|
| SA3-043-37K/45KF | 330.0 | 245.0 | 550.0 | 525.0 | 275.0 | 137.5 | 11.0 | 11.0 |
| SA3-043-45K/55KF | | | | | | | | |
| SA3-043-55K/75KF | | | | | | | | |
| SA3-043-75K/90KF | | | | | | | | |
| SA3-023-22K/30KF | | | | | | | | |
| SA3-023-30K/37KF | | | | | | | | |
| SA3-023-37K/45KF | | | | | | | | |

Frame E

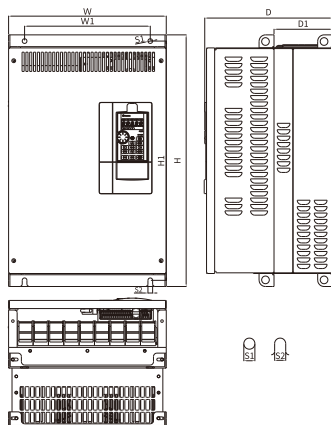

Frame E

| Model type | W (mm) | W1 (mm) | H (mm) | H1 (mm) | D (mm) | D1 (mm) | S1 (mm) | S2 (mm) |
|--------------------|--------|---------|--------|---------|--------|---------|---------|---------|
| SA3-043-90K/110KF | 370.0 | 295.0 | 589.0 | 560.0 | 300.0 | 137.5 | 11.0 | 11.0 |
| SA3-043-110K/132KF | | | | | | | | |
| SA3-023-45K/55KF | | | | | | | | |
| SA3-023-55K/75KF | | | | | | | | |

Frame F

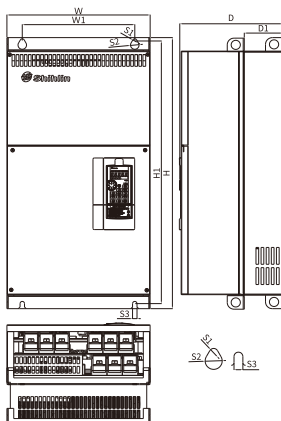

Frame F

| Model type | W (mm) | W1 (mm) | H (mm) | H1 (mm) | D (mm) | D1 (mm) | S1 (mm) | S2 (mm) | S3 (mm) |
|--------------------|--------|---------|--------|---------|--------|---------|---------|---------|---------|
| SA3-043-132K/160KF | 420.0 | 340.0 | 800.0 | 770.0 | 300.0 | 145.5 | 13.0 | 25.0 | 13.0 |
| SA3-023-75K/90KF | | | | | | | | | |



SA3

Dimensions

Unit: mm

Frame G

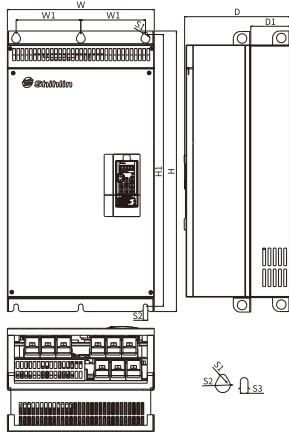

Frame G

| Model type | W (mm) | W1 (mm) | H (mm) | H1 (mm) | D (mm) | D1 (mm) | S1 (mm) | S2 (mm) | S3 (mm) |
|--------------------|--------|---------|--------|---------|--------|---------|---------|---------|---------|
| SA3-043-160K/185KF | 500.0 | 180.0 | 870.0 | 850.0 | 360.0 | 150.0 | 13.0 | 25.0 | 13.0 |
| SA3-043-185K/220KF | | | | | | | | | |
| SA3-043-220K/250KF | | | | | | | | | |
| SA3-043-250K/280KF | | | | | | | | | |
| SA3-023-90K/110KF | | | | | | | | | |
| SA3-023-110K/132KF | | | | | | | | | |

Frame H

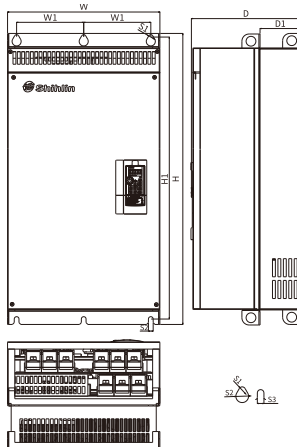

Frame H

| Model type | W (mm) | W1 (mm) | H (mm) | H1 (mm) | D (mm) | D1 (mm) | S1 (mm) | S2 (mm) | S3 (mm) |
|--------------------|--------|---------|--------|---------|--------|---------|---------|---------|---------|
| SA3-043-280K/315KF | 600.0 | 230.0 | 1000.0 | 980.0 | 400.0 | 181.5 | 13.0 | 25.0 | 13.0 |
| SA3-043-315K/355KF | | | | | | | | | |

Optional Accessory

Expansion Card - SF3 / SE3 / SA3 Series

PD302

Profibus communication expansion card



DN301

DeviceNet communication expansion card



CP301

CANopen communication expansion card



EP301

Ethernet communication expansion card



EB362R

I/O expansion card

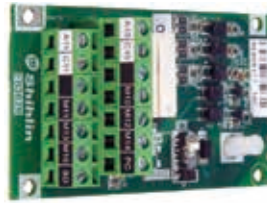

EB308R

I/O expansion card

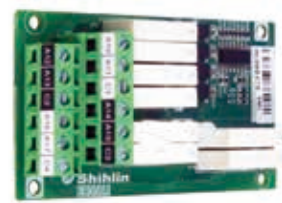

EC301-□□

EtherCAT communication expansion card

□□ SA3:A3, SE3:E3, SF3:F3



PG301C (SE3/SA3 Only)

Encoder feedback card (supports open collector type output)



PG301L (SE3/SA3 Only)

Encoder feedback card (supports differential type output)



PG302L (SE3/SA3 Only)

Encoder feedback card (supports Resolver signal)



CMK301 (SE3 Only)

For installing expansion card on SE3



Optional Accessory

Keypad

PU302



PU303



PU301C



PU301



DU06



DU10



DU08S



| No. | Series | Compatible Keypad | | | | | |
|-----|--------|-------------------|-------|-------|--------|-------|------|
| 1 | SL3 | PU301 | PU302 | PU303 | DU06 | DU08S | DU10 |
| 2 | SC3 | PU301 | PU302 | PU303 | DU06 | DU08S | DU10 |
| 3 | SS2 | PU301 | PU302 | PU303 | DU06 | DU08S | DU10 |
| 4 | SE3 | PU301 | PU302 | PU303 | \ | \ | \ |
| 5 | SF3 | PU301 | PU302 | PU303 | PU301C | \ | \ |
| 6 | SA3 | PU301 | PU302 | PU303 | PU301C | \ | \ |

Others

Data Cable



CBL1R5/03/05/10GTN2
(SL3/SC3/SF3/SA3)

RS-485 Adapter



USB01
USB to RS-485

AC/DC Reactor



Braking Unit (BKU)

Model Identification



BKU 040 45K XY

| Series | Voltage level | Capacity | Version |
|------------|----------------------------|----------|------------------------------------------------------------------------------|
| BKU series | -040 : 400V -020 : 200V | 37kW | None : General model -xy : Customized or specialized or region difference |
| | | 45kW | |
| | | 110kW | |
| | | 160kW | |

Feature

Durable appearance , IGBT modularized, great cooling, single and multi use. wiring friendly, can be used in variety brand of VFD

Dimension

Unit : mm

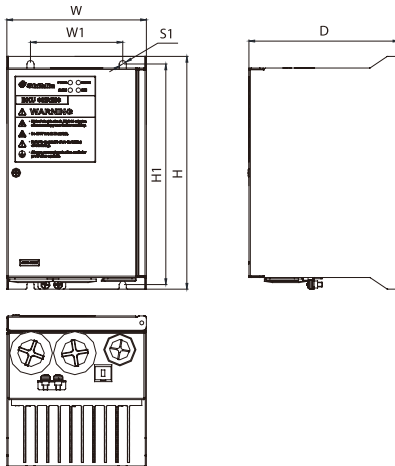

Frame A

| Model type | W (mm) | W1 (mm) | H (mm) | H1 (mm) | D (mm) | S1 (mm) |
|-------------|--------|---------|--------|---------|--------|---------|
| BKU-020-37K | 121 | 80 | 200 | 189.5 | 130 | 6.4 |
| BKU-040-45K | | | | | | |

Frame B

| Model type | W (mm) | W1 (mm) | H (mm) | H1 (mm) | D (mm) | S1 (mm) |
|--------------|--------|---------|--------|---------|--------|---------|
| BKU-020-110K | 233.5 | 193.5 | 343 | 329 | 190 | 6.4 |
| BKU-040-160K | | | | | | |

Braking Unit & Braking Resistor Application Table

| Voltage | Motor Rating | Equivalent Braking Resistor | Braking Unit | | Braking Resistor (20%ED, 125% Braking torque) | |
|---------|--------------|-----------------------------|--------------|------|-----------------------------------------------|------|
| | | | Model | Unit | Specification | Unit |
| 200V | 22kW | 10800W 6.8Ω | BKU-020-37K | 1 | 1200W 6.8R | 9 |
| | 30kW | 13500W 5Ω | BKU-020-37K | 1 | 1500W 5R | 9 |
| | 37kW | 21600W 4Ω | BKU-020-37K | 1 | 1200W 8R | 18 |
| | 45kW | 21600W 3.4Ω | BKU-020-37K | 2 | 1200W 6.8R | 18 |
| | 55kW | 27000W 2.5Ω | BKU-020-37K | 2 | 1500W 5R | 18 |
| | 75kW | 19200W 2Ω | BKU-020-37K | 2 | 1200W 8R | 16 |
| | 90kW | 25000W 2R | BKU-020-110K | 1 | 1000W 50R | 25 |
| | 110kW | 24000W 1.6R | BKU-020-110K | 1 | 1200W 8R | 20 |
| 400V | 37kW | 21600W 16Ω | BKU-040-45K | 1 | 1200W 8R | 18 |
| | 45kW | 21600W 13.6Ω | BKU-040-45K | 1 | 1200W 6.8R | 18 |
| | 55kW | 20000W 10Ω | BKU-040-45K | 2 | 1000W 50R | 20 |
| | 75kW | 43200W 6.8Ω | BKU-040-45K | 2 | 1200W 6.8R | 36 |
| | 90kW | 43200W 6.8Ω | BKU-040-45K | 2 | 1200W 6.8R | 36 |
| | 110kW | 36000W 5.6Ω | BKU-040-45K | 3 | 1000W 50R | 36 |
| | 132kW | 54000W 4.4Ω | BKU-040-45K | 3 | 1200W 8R | 45 |
| | 160kW | 38400W 4Ω | BKU-040-160K | 1 | 1200W 8R | 32 |
| | 185kW | 38400W 3.4Ω | BKU-040-160K | 2 | 1200W 6.8R | 32 |
| | 220kW | 57600W 2.7Ω | BKU-040-160K | 2 | 1200W 8R | 48 |
| | 250kW | 48000W 2.5Ω | BKU-040-160K | 2 | 1500W 5R | 32 |
| | 280kW | 67200W 2.3Ω | BKU-040-160K | 2 | 1200W 8R | 56 |
| | 315kW | 67200W 1.9Ω | BKU-040-160K | 2 | 1200W 6.8R | 56 |
| | 355kW | 72000W 1.7Ω | BKU-040-160K | 3 | 1500W 5R | 48 |

Note: If an adjustment of ED percentage is needed, please refer to the user manual for the connections of resistors.

SHIHLIN ELECTRIC & ENGINEERING

Transmission & Distribution, Electrical Products, Power Control, Switches & Breaker, Factory Automation, Automotive Electrical Components

Factory Automation Overseas Sales Division

3F, No.9, Sec. 1, Chang-an E. Rd., Zhongshan Dist., Taipei City 10441, Taiwan

T. +886-2-2541-9822 F. +886-2-2581-2665

e-mail: automation@seec.com.tw

<http://automation.seec.com.tw>

Headquarters

16F, No.88, Sec. 6, Zhongshan N. Rd., Shilin Dist., Taipei City 11155, Taiwan

T. +886-2-2834-2662 F. +886-2-2836-6187

<http://www.seec.com.tw>

Distributor

B230523E.INV-BO3